

TRIUMPH

REPLACEMENT PARTS

CATALOGUE No. 4

UNIT CONSTRUCTION 650 c.c. TWINS

6T THUNDERBIRD

TR6 TROPHY

T120 BONNEVILLE 120

From engine No. DU 24875

TRIUMPH ENGINEERING COMPANY LIMITED
MERIDEN WORKS · ALLESLEY · COVENTRY · ENGLAND
TELEPHONE MERIDEN 331 TELEGRAMS "TRUSTY COVENTRY"

ILLUSTRATION INDEX

Fig. No.	Description	Page No.
1	CRANKSHAFT AND CONNECTING RODS	20
2	CRANKCASE	22
3	OIL PUMP, RELEASE VALVE, MANIFOLD AND TAPPETS	24
4	CYLINDER BLOCK AND HEAD, 6T AND TR6	26
5	CYLINDER BLOCK AND HEAD, T120	28
6	TIMING COVER AND CONTACT BREAKER	30
7	GEARBOX INNER COVER AND SELECTORS	32
8	GEARBOX SHAFTS AND GEARS	34
9	GEARBOX OUTER COVER	36
10	CLUTCH	38
11	CHAINCASE AND CHAINS	40
12	FRAME	42
13	SWINGING FORK AND SUSPENSION UNITS	44
14	ENGINE UNIT FITTINGS AND FOOTRESTS	46
15	EXHAUST PIPES AND SILENCERS	48
16	EXHAUST PIPES AND MUFFLERS (U.S.A.)	50
17	TELESCOPIC FRONT FORKS, 6T	52
18	NACELLE HEADLAMP AND SWITCHES	54
19	TELESCOPIC FRONT FORK, TR6 AND T120	56
20	TELESCOPIC FRONT FORK, U.S.A. TR6C AND T120TT	58
21	FRONT WHEEL, 6T AND T120	60
22	FRONT WHEEL, TR6 AND U.S.A. T120	62
23	REAR WHEEL	64
24	QUICKLY DETACHABLE REAR WHEEL	66
25	PETROL (GAS) TANKS	68
26	OIL TANK	70
27	BATTERY CARRIER AND AIR FILTERS	72
28	PANEL AND TWINSEAT	74
29	MUDGUARDS (STANDARD)	76
30	FENDERS (U.S.A.)	78
31	HANDLEBARS AND CONTROL LEVERS	80
32	CONTROL CABLES AND AMERICAN HANDLEBARS	82
33	TOOLKIT, FRAME LOCK, PILLION FOOTRESTS AND LICENCE HOLDER	84
34	AMAL CARBURETTER, 6T	86
35	AMAL CARBURETTER, TR6 AND T120	88
36	AMAL CARBURETTER, T120TT	90
37	SPEEDOMETER AND TACHOMETER	92
38	A.C. MAGNETO IGNITION COILS AND DIRECT LIGHTING	94
39	D.C. IGNITION COILS, HORN, RECTIFIER AND ZENER DIODE	96
40	HEADLAMP, WIRING HARNESS, SWITCHES AND TAIL LAMP	98

INDEX

	<i>Page</i>		<i>Page</i>
AIR FILTER	73	MANIFOLD	25
ALTERNATOR	21, 41	MUDGUARDS	77
BATTERY CARRIER	73	MUFFLERS	51
CARBURETTER	87, 89, 91	NACELLE	55
CARTON PACKS	16	OIL PUMP	25
CENTRE STAND	43	OIL TANK	71
CHAINCASE	41	PETROL TANK	69
CHAINS	41	PILLION FOOTRESTS	85
CLUTCH	39	PISTONS	21
COIL	95, 97	PROP STAND	43
CONTACT BREAKER	31	Q.D. REAR WHEEL	67
CONTROL CABLES	83	REAR PANEL	75
CONTROL LEVERS	81	REAR WHEEL	65
CRANKCASE	23	RECTIFIER	97
CRANKSHAFT	21	SILENCERS	49
CYLINDER HEAD	27, 29	SPARK PLUGS	97
ENGINE PLATES	47	SPEEDOMETER	93
EXHAUST PIPES	49, 51	STEERING RACES	43
FENDERS	47	SUSPENSION UNITS	45
FOOTRESTS	47	SWITCHES	55, 99
FRONT FORKS	53, 57, 59	TIMING GEARS	21
FRONT WHEEL	61, 63	TOOLKIT	85
GAS TANKS	69	TWINSEAT	75
GASKET SETS	17	VALVES	27, 29
GEARBOX	33, 35, 37	WIRING HARNESS	55, 95, 99
HANDLEBARS	81, 83	ZENER DIODE	97
HORN	55, 95, 97		

MODEL GROUPING CHART

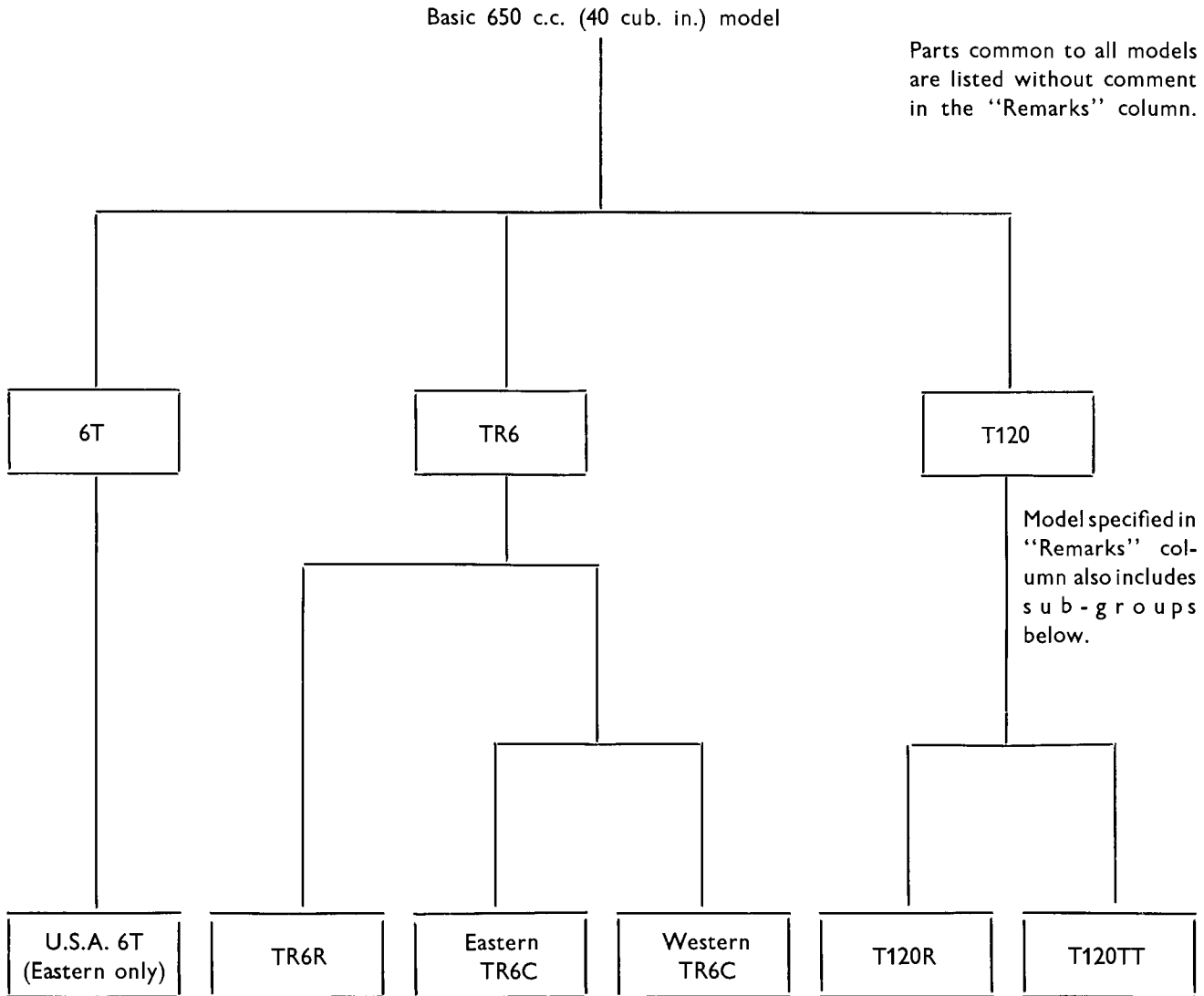

Parts unique to particular models are indicated by model number in the "Remarks" column.

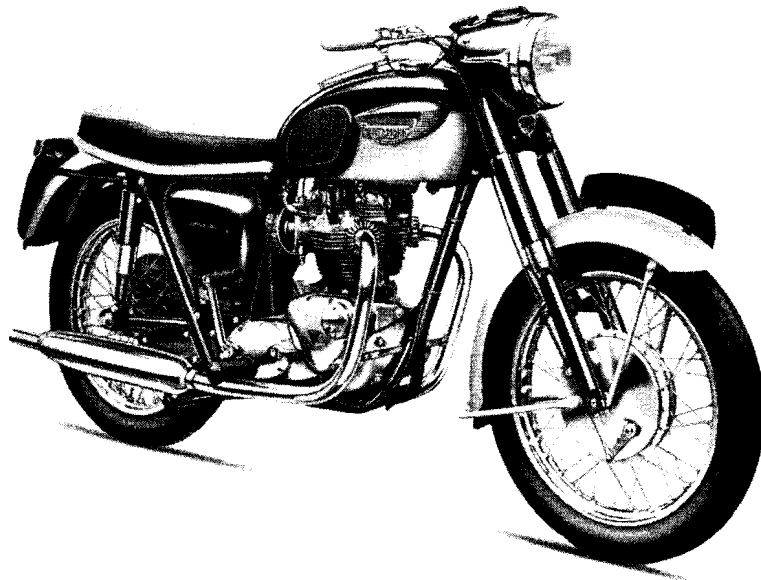

THUNDERBIRD (6T) TECHNICAL DATA

Bore and stroke	71x82 mm. 2.79x3.23 ins.
Capacity	649 c.c. (40 cu. ins.)
Compression ratio	7.5 : 1
Sparking plugs	Champion N4
Carburetter	Amal Monobloc 376
					Main jet	230
					Needle jet106
					Needle	Type C
					Throttle valve	376/4
					Pilot jet	25
Gearbox sprocket	Solo	20 teeth
				Sidecar	18 teeth
Chains	Front	$\frac{3}{8}$ " Duplex x 84 links
				Rear	Solo	...	$\frac{5}{8}$ " x $\frac{3}{8}$ " x 103 links
					Sidecar	...	$\frac{5}{8}$ " x $\frac{3}{8}$ " x 102 links
Capacities	Fuel Tank	4 galls. (18 litres)
				Oil Tank	5 pints (2.8 litres)
				Gearbox	$\frac{7}{8}$ pint (500 c.c.)
				Primary Chaincase	$\frac{5}{8}$ pint (350 c.c.)
				Front Forks (each leg)	$\frac{1}{2}$ pint (190 c.c.)
Brakes	Front, diameter...	8" (20.32 cms.)
				Rear, diameter	7" (17.78 cms.)
Tyre size	Front	3.25x18
				Rear	3.50x18

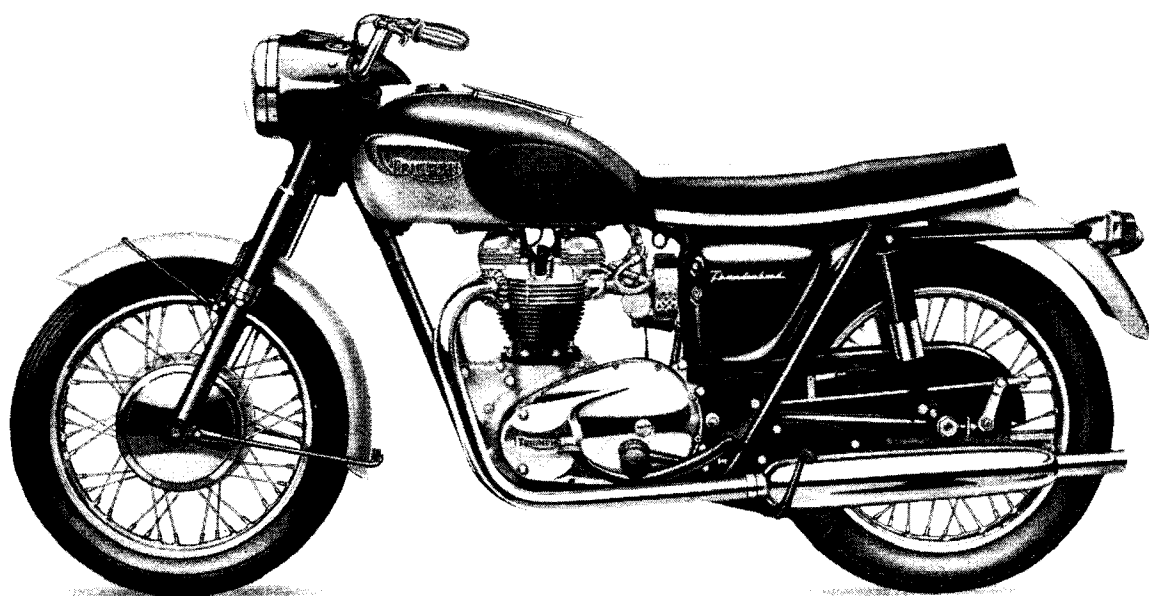

U.S.A. THUNDERBIRD (6T) TECHNICAL DATA

Bore and stroke	71 x 82 mm. 2.79 x 3.23 ins.
Capacity	649 c.c. (40 cu. ins.)
Compression ratio	7.5 : 1
Spark plugs	Champion N4
Carbureter	Amal Monobloc 376
										Main jet 270
										Needle jet 106
										Needle Type C
										Throttle valve 376/4
										Pilot jet 25
Gearbox sprocket	18 teeth
Chains	Front $\frac{3}{8}$ " Duplex x 84 links
										Rear $\frac{5}{8}$ " x $\frac{3}{8}$ " x 102 links
Capacities	Gas Tank $3\frac{3}{4}$ U.S. galls. (16 litres)
										Oil Tank 6 U.S. pints (2.8 litres)
										Gearbox $\frac{7}{8}$ pint (500 c.c.)
										Primary Chaincase $\frac{5}{8}$ pint (350 c.c.)
										Front Forks (each leg) $\frac{1}{3}$ pint (190 c.c.)
Brakes	Front, diameter... .. 8" (20.32 cms.)
										Rear, diameter 7" (17.78 cms.)
Tire size	Front 3.25 x 18
										Rear 3.50 x 18

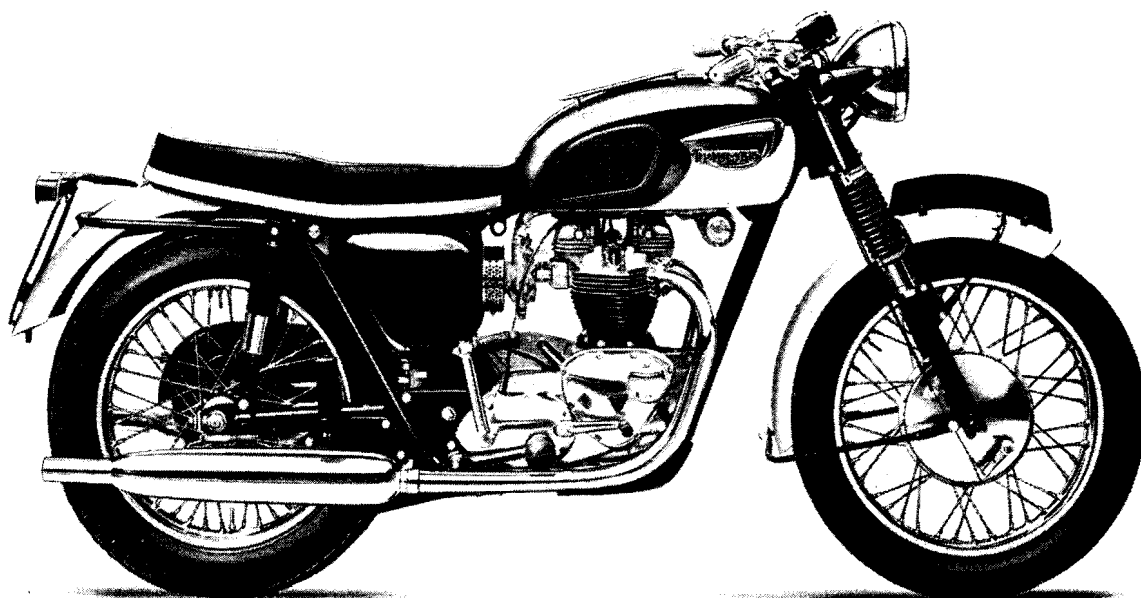

TROPHY (TR6) TECHNICAL DATA

Bore and stroke	71 x 82 mm. 2.79 x 3.23 ins.
Capacity	649 c.c. (40 cu. ins.)
Compression ratio	8.5 : 1
Sparking plugs	Champion N4
Carburetter	Amal Monobloc 389
					Main jet	310
					Needle jet106
					Needle	Type D
					Throttle valve	389/3½
					Pilot jet	25
Gearbox sprocket	19 teeth
Chains	Front	¾" Duplex x 84 links
					Rear	5/8" x 3/8" x 103 links
Capacities	Fuel Tank	4 galls. (18 litres)
					Oil Tank	5 pints (2.8 litres)
					Gearbox	7/8 pint (500 c.c.)
					Primary Chaincase	5/8 pint (350 c.c.)
					Front Forks (each leg)	½ pint (190 c.c.)
Brakes	Front, diameter	8 in. (20.32 cm.)
					Rear, diameter	7 in. (17.78 cm.)
Tyre size	Front	3.25 x 19
					Rear	4.00 x 18

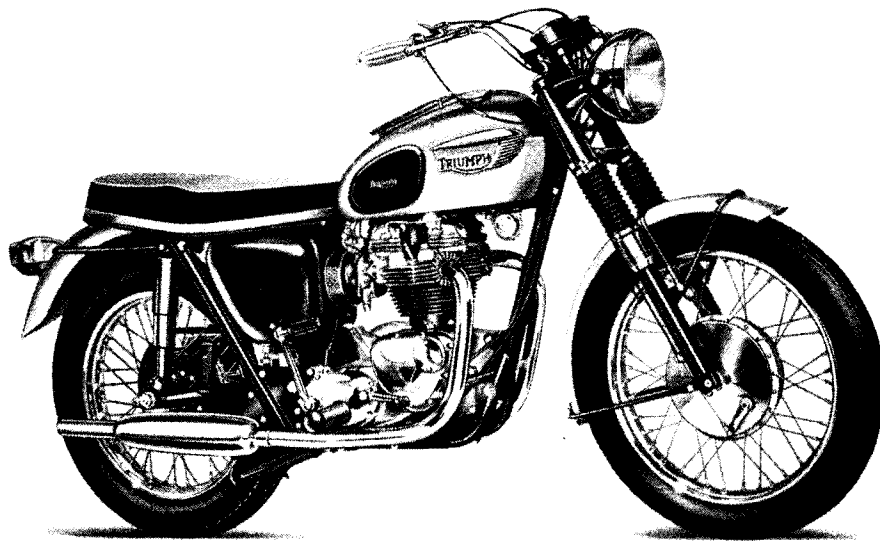

U.S.A. TROPHY (TR6R) TECHNICAL DATA

Bore and stroke...	71 x 82 mm. 2.79 x 3.23 ins.
Capacity	649 c.c. (40 cu. ins.)
Compression ratio	8.5 : 1
Spark plugs	Champion N4
Carbureter	Amal Monobloc 389
				Main jet	310
				Needle jet106
				Needle	Type D
				Throttle valve	389/3½
				Pilot jet	25
Gearbox sprocket	19 teeth
Chains	Front	¾" Duplex x 84 links
				Rear	5/8" x 3/8" x 103 links
Capacities	Gas Tank	3¾ U.S. galls. (16 litres)
				Oil Tank	6 U.S. pints (2.8 litres)
				Gearbox	7/8 pint (500 c.c.)
				Primary Chaincase	5/8 pint (350 c.c.)
				Front Forks (each leg)	1/3 pint (190 c.c.)
Brakes	Front, diameter...	8" (20.32 cm.)
				Rear, diameter	7" (17.78 cm.)
Tire size	Front	3.25 x 19
				Rear	4.00 x 18

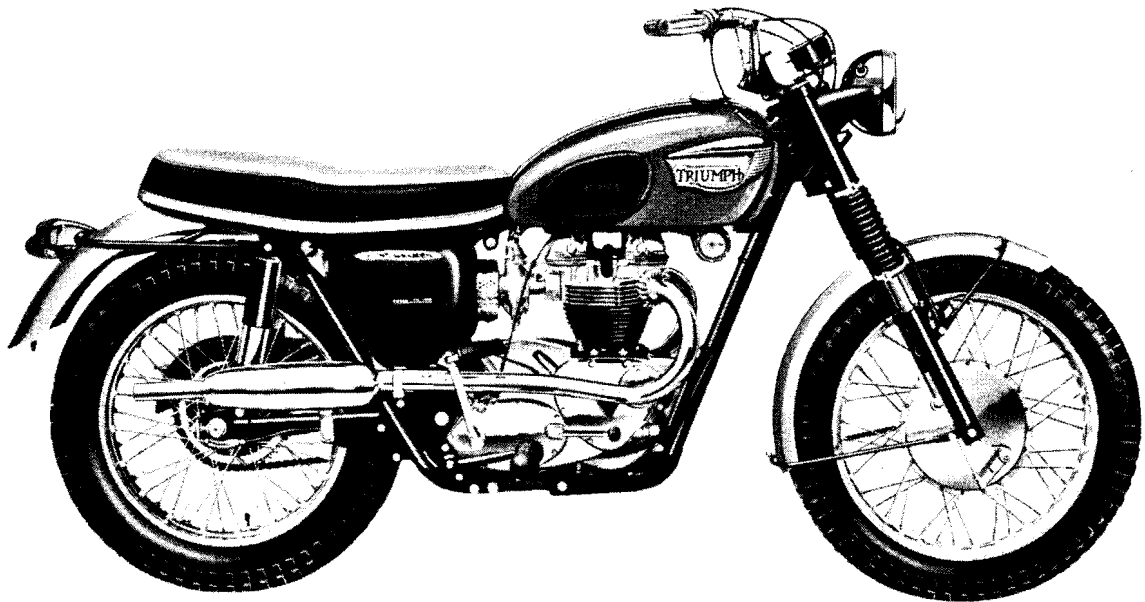

EASTERN U.S.A. TROPHY (TR6C) TECHNICAL DATA

Bore and stroke...	71 x 82 mm. 2.79 x 3.23 ins.
Capacity	649 c.c. (40 cu. ins.)
Compression ratio	8.5 : 1
Spark plugs	Champion N4
Carbureter	Amal Monobloc 389
				Main jet	310
				Needle jet106
				Needle	Type D
				Throttle valve	389/3½
				Pilot jet	25
Gearbox sprocket	18 teeth
Chains	Front	¾" Duplex x 84 links
				Rear	5/8" x 3/8" x 103 links
Capacities	Gas Tank	2¾ U.S. galls. (11 litres)
				Oil Tank	6 U.S. pints (1.8 litres)
				Gearbox	7/8 pint (500 c.c.)
				Primary Chaincase	¾ pint (350 c.c.)
				Front Forks (each leg)	½ pint (190 c.c.)
Brakes	Front, diameter	8" (20.32 cm.)
				Rear, diameter	7" (17.78 cm.)
Tire size	Front	3.25 x 19
				Rear	4.00 x 18

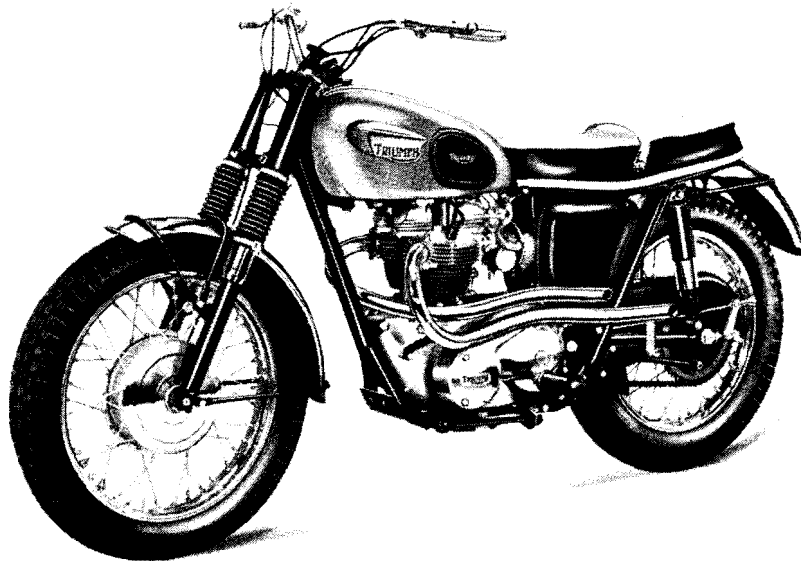

WESTERN U.S.A. TROPHY (TR6C) TECHNICAL DATA

Bore and stroke...	71 x 82 mm. 2.79 x 3.23 ins.
Capacity	649 c.c. (40 cu. ins.)
Compression ratio	8.5 : 1
Spark plugs	Champion N4
Carbureter	Amal Monobloc 389
				Main jet	310
				Needle jet106
				Needle	Type D
				Throttle valve	389/3½
				Pilot jet	25
Gearbox sprocket	17 teeth
Chains	Front	¾" Duplex x 84 links
				Rear	⅝" x ⅜" x 102 links
Capacities	Gas Tank	3¾ U.S. galls. (16 litres)
				Oil Tank	6 U.S. pints (2.8 litres)
				Gearbox	⅞ pint (500 c.c.)
				Primary Chaincase	⅝ pint (350 c.c.)
				Front Forks (each leg)	⅓ pint (190 c.c.)
Brakes	Front, diameter...	8" (20.32 cm.)
				Rear, diameter	7" (17.78 cm.)
Tire size	Front	3.25 x 19
				Rear	4.00 x 18

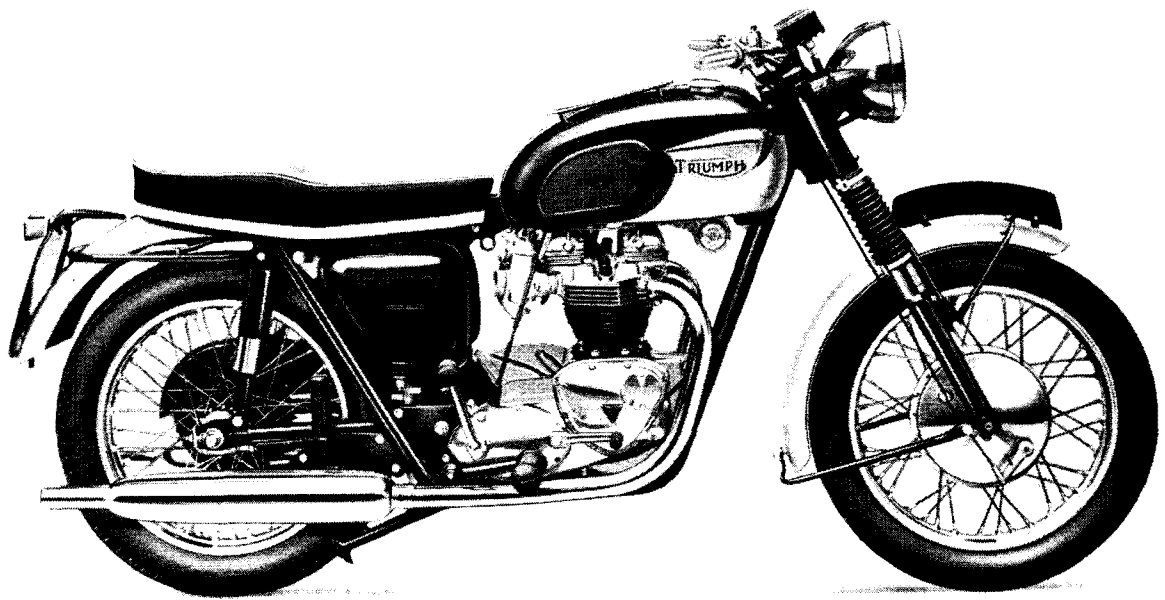

BONNEVILLE 120 (T120) TECHNICAL DATA

Bore and stroke	71x82 mm. 2.79x3.23 ins.
Capacity	649 c.c. (40 cu. ins.)
Compression ratio	9 : 1
Sparking plugs	Champion N4
Carburetters	2 Amal Monobloc 389
					Main jet	260
					Needle jet106
					Needle	Type D
					Throttle valve	389/3
					Pilot jet	25
Gearbox sprocket	19 teeth
Chains	Front	$\frac{3}{8}$ " Duplex x 84 links
					Rear	$\frac{5}{8}$ " x $\frac{3}{8}$ " x 103 links
Capacities	Fuel Tank	4 galls. (18 litres)
					Oil Tank	5 pints (2.8 litres)
					Gearbox	$\frac{7}{8}$ pint (500 c.c.)
					Primary Chaincase	$\frac{3}{8}$ pint (350 c.c.)
					Front Forks (each leg)	$\frac{1}{3}$ pint (190 c.c.)
Brakes	Front, diameter	8 in. (20.32 cm.)
					Rear, diameter	7 in. (17.78 cm.)
Tyre size	Front	3.25 x 18
					Rear	3.50 x 18

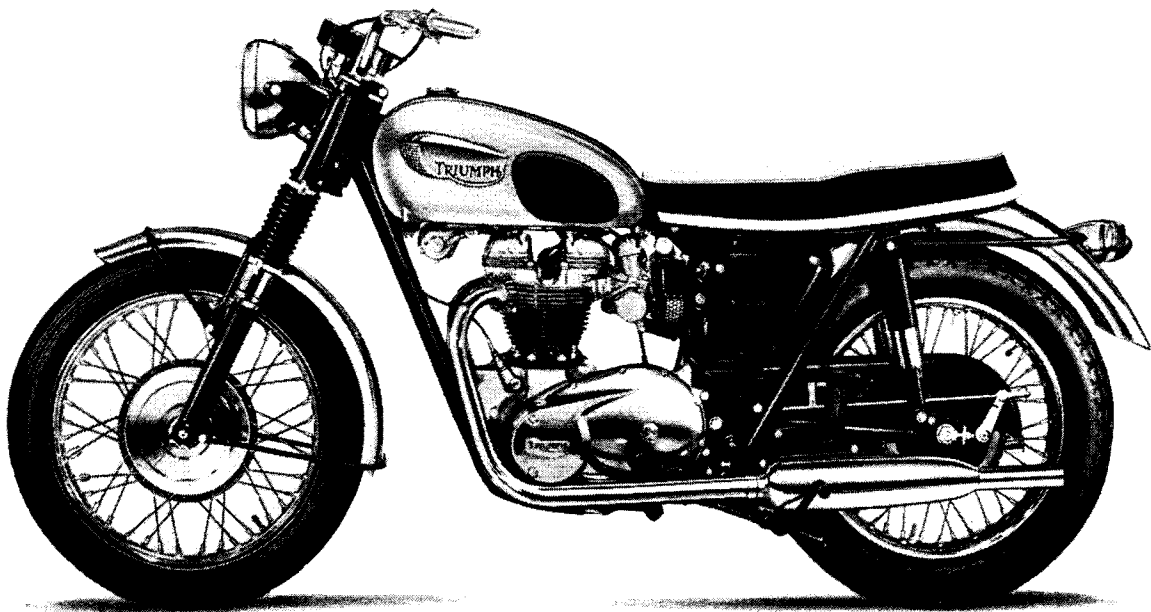

U.S.A. BONNEVILLE 120 (T120R) TECHNICAL DATA

Bore and stroke...	71 x 82 mm. 2.79 x 3.23 ins.
Capacity	649 c.c. (40 cu. ins.)
Compression ratio	9 : 1
Spark plugs	Champion N4
Carbureters	2 Amal Monobloc 389
				Main jet	260
				Needle jet106
				Needle	Type D
				Throttle valve	389/3
				Pilot jet	25
Gearbox sprocket	19 teeth
Chains	Front	$\frac{3}{8}$ " Duplex x 84 links
				Rear	$\frac{5}{8}$ " x $\frac{3}{8}$ " x 103 links
Capacities	Gas Tank	2 $\frac{3}{4}$ U.S. galls. (11 litres)
				Oil Tank	5 U.S. pints (2.8 litres)
				Gearbox	$\frac{7}{8}$ pint (500 c.c.)
				Primary Chaincase	$\frac{5}{8}$ pint (350 c.c.)
				Front Forks (each leg)	$\frac{1}{3}$ pint (190 c.c.)
Brakes	Front, diameter...	8" (20.32 cm.)
				Rear, diameter	7" (17.78 cm.)
Tire size	Front	3.25 x 19
				Rear	4.00 x 18

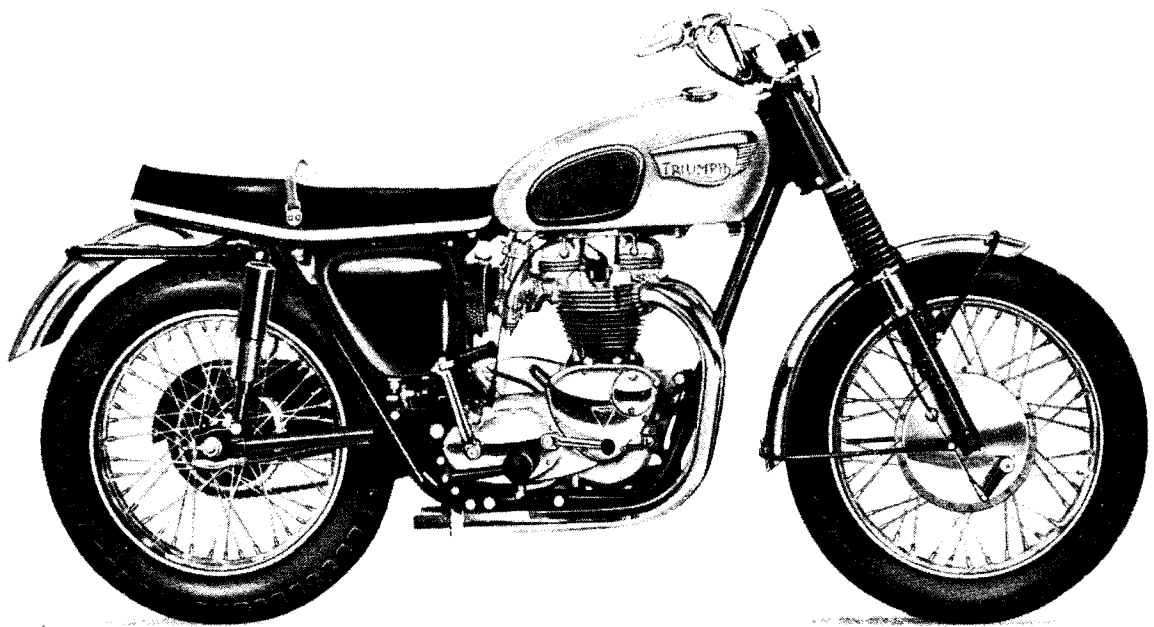

U.S.A. BONNEVILLE 120 (T120TT) TECHNICAL DATA

Bore and stroke...	71 x 82 mm. 2.79 x 3.23 ins.
Capacity	649 c.c. (40 cu. ins.)
Compression ratio	11 : 1
Spark plugs	Champion N58R
Carbureters	2 Amal Monobloc 389
										Main jet ... 330
										Needle jet ... 106
										Needle ... Type D
										Throttle valve ... 389/4
										Pilot jet ... 25
Gearbox sprocket	17 teeth
Chains	Front ... $\frac{3}{8}$ " Duplex x 84 links
										Rear ... $\frac{5}{8}$ " x $\frac{3}{8}$ " x 102 links
Capacities	Gas Tank ... 2 $\frac{3}{4}$ U.S. galls. (11 litres)
										Oil Tank ... 6 U.S. pints (2.8 litres)
										Gearbox ... $\frac{7}{8}$ pint (500 c.c.)
										Primary Chaincase ... $\frac{5}{8}$ pint (350 c.c.)
										Front Forks (each leg) ... $\frac{1}{3}$ pint (190 c.c.)
Brakes	Front, diameter... 8" (20.32 cm.)
										Rear, diameter ... 7" (17.78 cm.)
Tire size	Front ... 3.25 x 19
										Rear ... 4.00 x 18

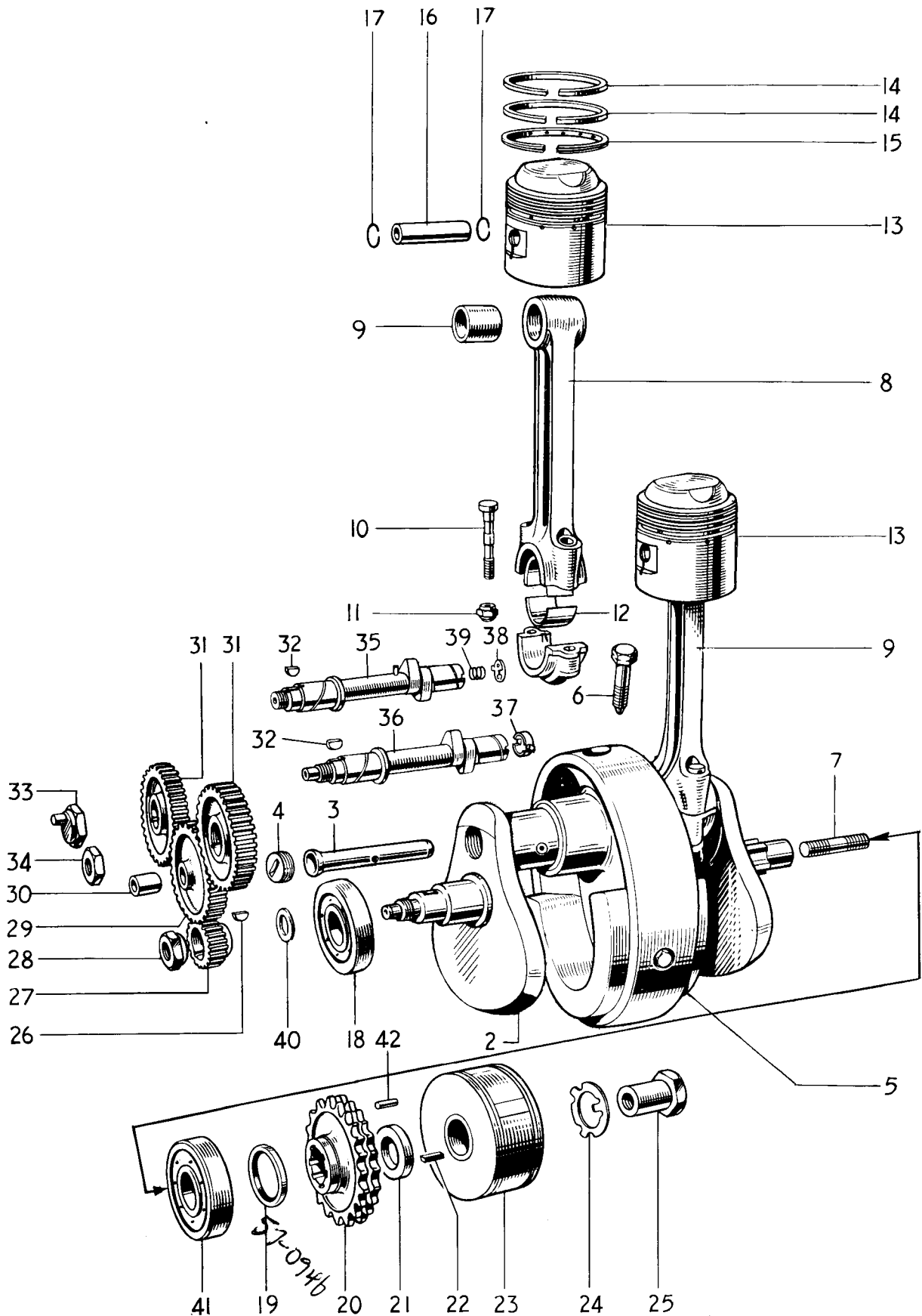

Fig. 1. CRANKSHAFT AND CONNECTING RODS

CRANKSHAFT AND CONNECTING RODS

1	E6326	CRANKSHAFT AND FLYWHEEL ASSEMBLY	1	
2	E4643	CRANKSHAFT C/W. OIL TUBE	1	
3	E3903	Oil tube	1	
4	E3905	Screwed plug	1	
5	E6327	Flywheel	1	
6	*E6328	Flywheel bolt	3	
7	E3114	Crankshaft stud (1 $\frac{3}{8}$ " O.A.)	1	
8	E3606T	CONNECTING ROD	2	
9	E1511	Small end bush	2	
10	E2490A	Connecting rod bolt	4	
11	E2922	Self locking nut	4	
12	E3586	Big end bearing	4	
13	CP199	PISTON COMPLETE 7.5 : 1 C.R.	2	6T
13	CP200	PISTON COMPLETE 8.5 : 1 C.R.	2	TR6
13	CP206	PISTON COMPLETE 9 : 1 C.R.	2	T120 & T120R
13	CP202	PISTON COMPLETE 11 : 1 C.R.	2	T120TT
14	E3049	Taper compression ring	4	
15	E2898	Oil control ring	2	
16	WE203E	Gudgeon pin	2	
17	WE479	Circlip	4	
18	E1591	Main bearing, right	1	
19	E3876	Oil seal	1	
20	E5446	Engine sprocket, 29 teeth Duplex	1	
20	E5450	Engine sprocket, 29 teeth Duplex	1	A.C. Ignition
21	E4573	Distance piece	1	
21	E4912	Distance piece	1	A.C. Ignition
22	E3974	Rotor key	1	
23	54213901	Rotor, type RM19	1	
23	54215824	Rotor, type RM19	1	A.C. Ignition
24	E3975	Tab washer	1	
25	E3977	Nut	1	
26	E1580	Key	1	
27	E4564	Timing pinion	1	
28	E4565	Nut	1	
29	E6159	INTERMEDIATE WHEEL	1	
30	E400	Intermediate wheel bush...	1	
31	E4562	Camshaft wheel...	2	
32	E1558	Camshaft key	2	
33	E1463	Inlet camshaft nut	1	
34	E4563	Exhaust camshaft nut	1	
35	E4818	Inlet camshaft	1	6T
35	E4819	Inlet camshaft	-	TR6 & T120
36	E4848	Exhaust camshaft	1	6T
36	E4855	EXHAUST CAMSHAFT	-	TR6 & T120
37	E4700	Tachometer drive thimble	-	
38	E5316	Rotary breather valve	1	
39	E2256	Breather valve spring	1	
40	E3300	Clamping washer	1	
41	E2879	Main bearing, left	1	
42	E4913	Dowel	1	A.C. Ignition

* Use D524 Loctite Sealant

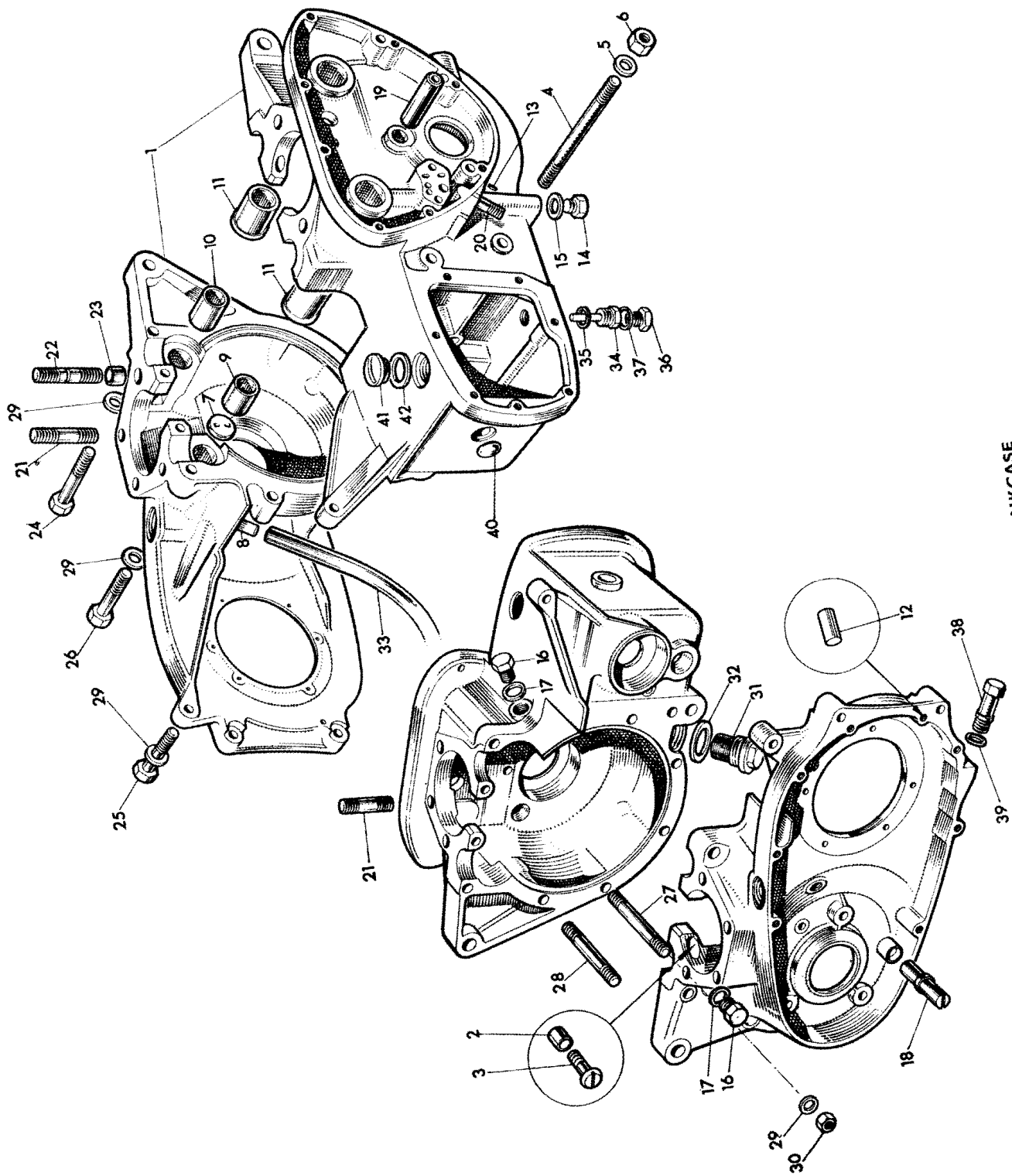

FIG. 2. CRANKCASE

CRANKCASE

1	E5871/6303	CRANKCASE	1	
2	E3716	Hollow Dowel	1	
3	E5232	Screw ($\frac{21}{32}$ in. U.H.)	2	
4	E4542	Stud ($4\frac{1}{2}$ in. O.A.)	2	
5	S25-2	Plain washer	2	
6	P0172A	Nut	2	
7	GS87	Breather disc	1	
8	E2724	Breather pipe	1	
9	E2260	Inlet camshaft bush	1	
10	E1516	Exhaust camshaft bush	1	
11	E1479	Camshaft bush	2	
12	E5616	Blanking plug	1	
13	E6386	Locating peg	1	Not serviced
14	E4539	Oilway plug	1	
15	F1880	Copper washer	1	
16	E4706	Tachometer drive plug	2	
17	E697	Fibre washer	2	
18	E5976	Chain tensioner abutment	1	
19	E375	Intermediate wheel spindle	1	
20	E3717	Oil pipe stud ($1\frac{1}{2}$ in. O.A.)	1	
21	E672	Cylinder stud ($1\frac{5}{8}$ in. O.A.)	6	
22	E3523	Cylinder stud ($1\frac{5}{8}$ in. O.A.)	2	
23	E1534A	Hollow dowel	2	
24	E4541	Bolt ($2\frac{1}{2}$ in. U.H.)	1	
25	E4540	Bolt ($1\frac{3}{4}$ in. U.H.)	1	
26	E4098	Bolt ($1\frac{7}{8}$ in. U.H.)	1	
27	E4856	Stud ($5\frac{1}{16}$ in. O.A.)	1	
28	E2888	Stud ($3\frac{7}{8}$ in. O.A.)	3	
29	S25-3	Plain washer	11	
30	S1-51	Nut	8	
31	E5312	Crankcase filter... ..	1	
32	E5315	Copper washer	1	
33	E5375	Breather extension pipe	1	
34	T1112	Drain plug (with level tube)	1	
35	T1257	Fibre washer	1	
36	T361	Level plug	1	
37	E2441	Copper washer	1	
38	E6347	Drain and adjuster plug	1	
39	T1738	Fibre washer	1	
40	T1920	Blanking plug	1	
41	E732	Filler plug	2	
42	NE507	Fibre washer	2	

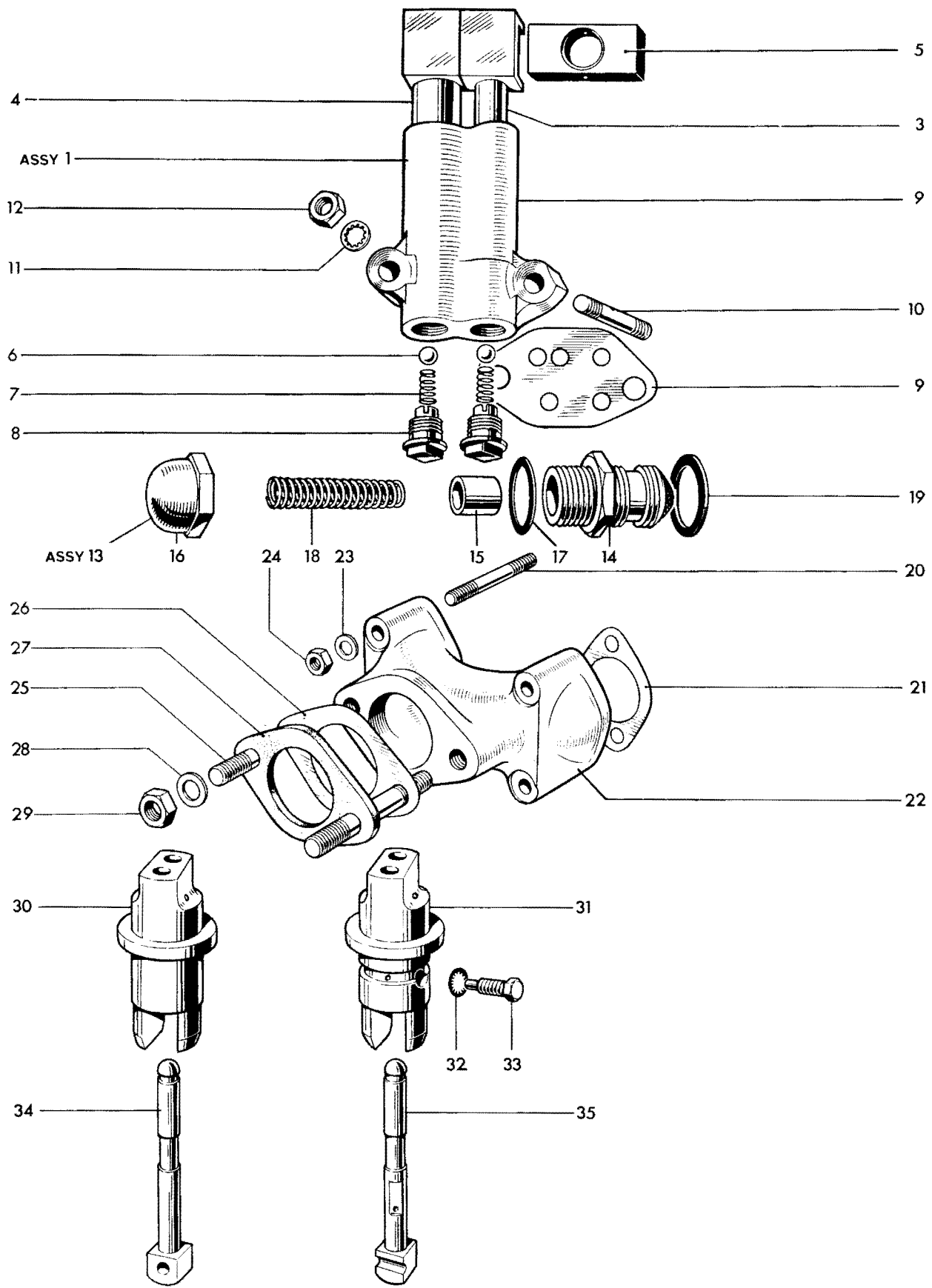

Fig. 3. OIL PUMP, RELEASE VALVE, MANIFOLD AND TAPPETS

OIL PUMP, RELEASE VALVE, MANIFOLD AND TAPPETS

1	E3878	OIL PUMP	1	
2	E3731	Pump body...	1	
3	GS153	Feed plunger	1	
4	E1476	Scavenge plunger	1	
5	E495	Drive block	1	
6	S70-7	Valve ball ($\frac{7}{32}$ in. dia.)	2	
7	E403	Valve spring	2	
8	E2360	Screwed plug	2	
9	E3730	Joint washer	1	
10	E3718	Oil pump stud ($1\frac{5}{16}$ in. U.H.)	2	
11	E3887	Serrated washer	2	
12	E3732	Nut	2	
13	E5896	OIL RELEASE VALVE	1	
14	E2794	Valve body	1	
15	GS251	Piston	1	
16	E2304	Cap	1	
17	GS254	Fibre washer	1	
18	E6062	Main spring	1	
19	E1670	Fibre washer	1	
20	E2973	Stud ($1\frac{5}{8}$ in. O.A.)	4	
21	E3334	Joint washer	2	
22	E3304	Inlet manifold	1	
23	S25-13	Plain washer	4	
24	W103	Nut	4	
25	E2962	Stud ($1\frac{7}{32}$ in. O.A.)	2	
26	NA43A	Joint washer	1	
27	E2968	Insulating block	1	
28	S25-3	Plain washer	2	
29	S1-51	Nut	2	
30	E4676	Inlet tappet guide	1	
31	E5861	Exhaust tappet guide	1	
32	E1612	Serrated washer	2	
33	H200	Set bolt	2	
34	E3059	Inlet tappet	2	6T, TR6
34	E3059R	Inlet tappet	2	T120
35	E6329	Exhaust tappet	2	6T, TR6
35	E6490	Exhaust tappet	2	T120

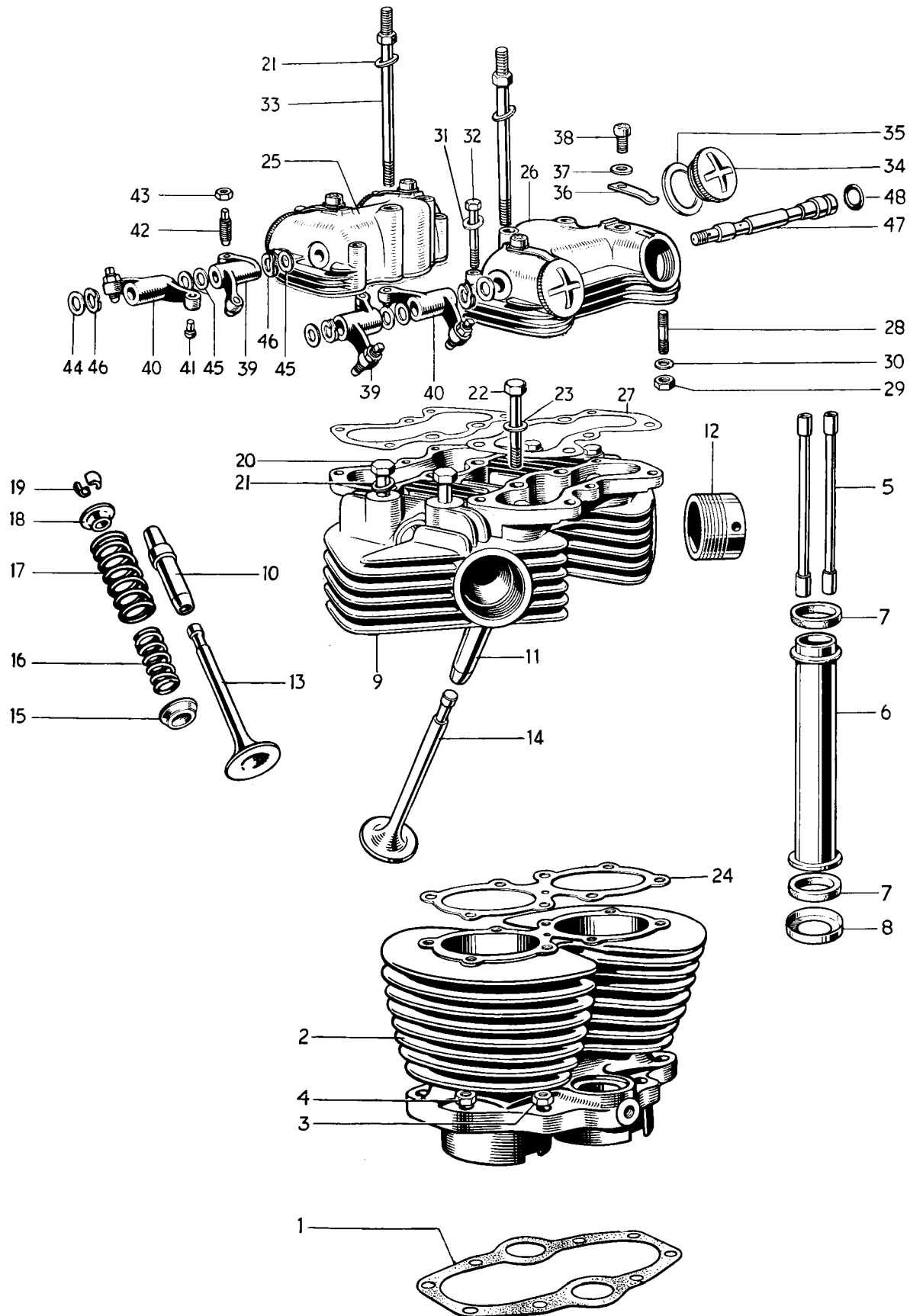

Fig. 4. CYLINDER BLOCK AND HEAD, 6T AND TR6

CYLINDER BLOCK AND HEAD, 6T AND TR6

1	E6309	Cylinder base washer	1	
2	E6304	Cylinder block	1	
3	W76	Inner cylinder base nut	4	
4	P0172A	Outer cylinder base nut	4	
5	E2620	Push rod	4	
6	E6000	Cover tube	2	
7	E3547	Rubber washer	4	
8	E4746	Bottom cup	2	
9	E4552	CYLINDER HEAD c/w GUIDES	1	
10	E2899	Inlet valve guide	2	
11	E2900	Exhaust valve guide	2	
12	E5914	Exhaust pipe adaptor	2	
13	E3310	Inlet valve	2	
14	E3927	Exhaust valve	2	
15	E5008	Bottom cup	4	6T
15	E6439	Bottom cup	4	TR6
16	E4221	Inner valve spring (red spot)	4	
17	E4222	Outer valve spring (red spot)	4	
18	E1543	Top collar	4	
19	WE259A	Split cotter	8	
20	E327	Cylinder head bolt (3 $\frac{3}{8}$ in. U.H.)	4	
21	F2184	Plain washer	8	
22	E4771	Bolt (3 in. U.H.)	1	
23	S25-3	Plain washer	1	
24	E4547	Cylinder head gasket	1	
25	E4550	Inlet rocker box	1	
26	E4551	Exhaust rocker box	1	
27	E4549	Joint washer	2	
28	E2980	Rocker box stud ($1\frac{5}{8}$ in. O.A.)	6	
29	F879	Rocker box nut... ..	6	
30	E3302	Plain washer	6	
31	E2982	Rocker box bolt (2 $\frac{5}{32}$ in. U.H.)	4	
32	S25-13	Plain washer	4	
33	E1596	Cylinder head bolt (for torque stay)	4	
34	E4610	Inspection cap	4	
35	E3751	Joint washer	4	
36	E4609	Locking spring	4	
37	WE170	Fibre washer	4	
38	T1553	Screw ($\frac{3}{8}$ in. U.H.)	4	
39	E1457	ROCKER (right exhaust, left inlet)	2	
40	E1458	ROCKER (left exhaust, right inlet)	2	
41	E1483	Rocker ball pin	4	
42	E1513	Rocker adjusting pin	4	
43	E470	Adjuster lock nut	4	
44	E1330	Thrust washer, $\frac{3}{8}$ in.	2	
45	E1575	Thrust washer, $\frac{1}{2}$ in.	6	
46	E1574	Spring washer	4	
47	E1512	Rocker spindle	2	
48	E3253	Sealing rubber	2	

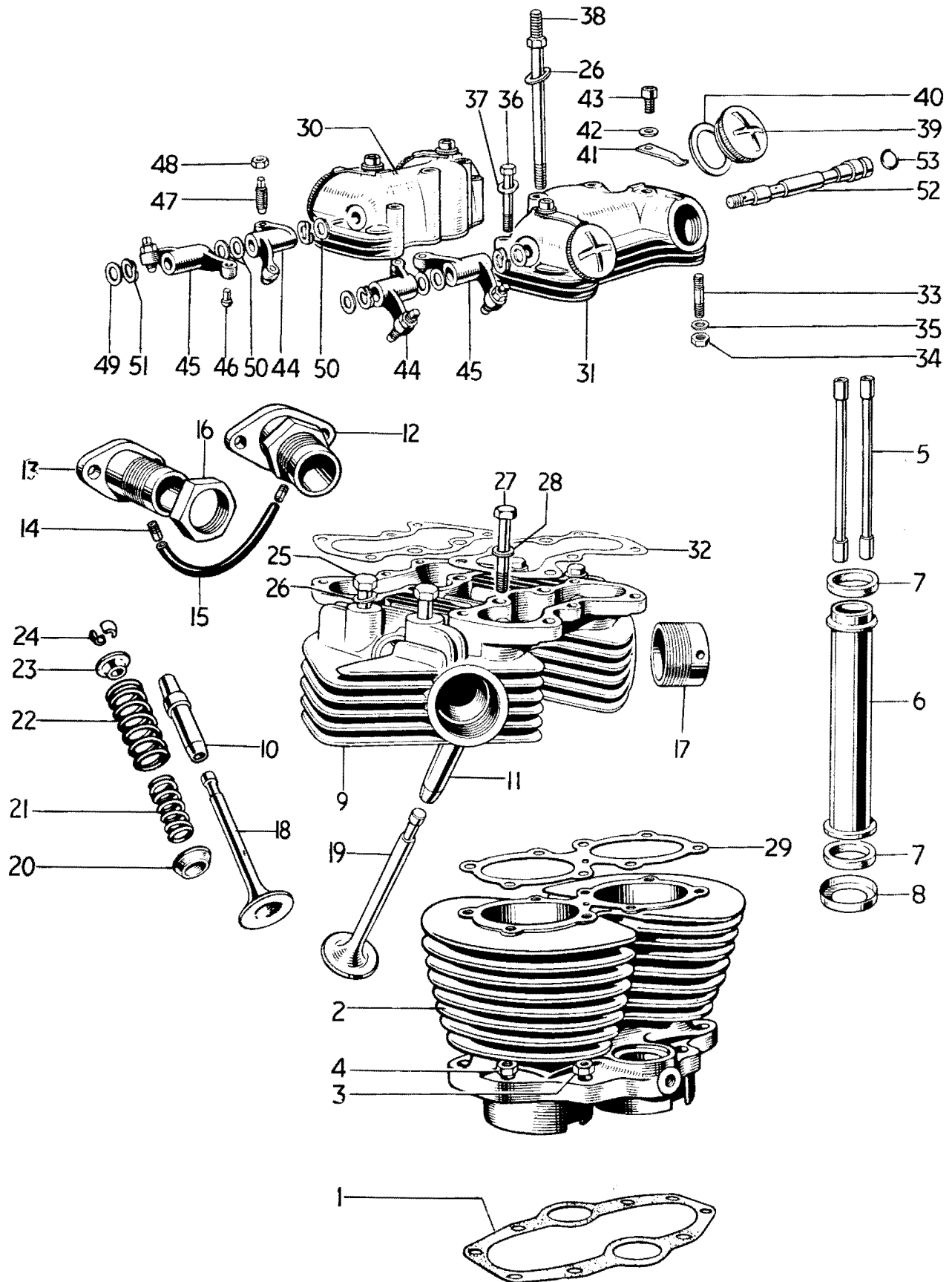

Fig. 5. CYLINDER BLOCK AND HEAD, T120

Ref. No.	Part No.	DESCRIPTION	QUANTITY	REMARKS
CYLINDER BLOCK AND HEAD, T120				
1	E6309	Cylinder base washer	1	
2	70- E6304	Cylinder block ... <i>199.78</i>	1	
3	W76	Inner cylinder base nut	4	
4	P0172A	Outer cylinder base nut	4	
5	E2620	Push rod	4	
6	E6000	Cover tube	2	
7	E3547	Rubber washer	4	
8	E4746	Bottom cup	2	
9	E5348	CYLINDER HEAD c/w GUIDES	1	Use E5727 for T120TT
10	E3827	Inlet valve guide	2	
11	E3828	Exhaust valve guide	2	
12	E5349	Carburetter adaptor, left	1	Use E5351 for T120 T Use E5352 for T120 T
13	E5350	Carburetter adaptor, right	1	
14	E4791	Connector	2	
15	E4792	Balance pipe	1	
16	E4608	Adaptor locking nut	2	
17	E5914	Exhaust pipe adaptor	2	
18	E4603	Inlet valve	2	
19	E2904	Exhaust valve	2	
10	E6439	Bottom cup	2	
21	E4221	Inner valve spring (Red spot)	4	
22	E4222	Outer valve spring (Red spot)	4	
23	E1543	Top collar	4	
24	WE259A	Split cotter	8	
25	E327	Cylinder head bolt (3 $\frac{3}{8}$ in. U.H.)	4	
26	F2184	Plain washer	8	
27	E4771	Bolt (3 in. U.H.)	1	
28	S25-3	Plain washer	1	
29	E4547	Cylinder head gasket	1	
30	E4550	Inlet rocker box	1	
31	E4551	Exhaust rocker box	1	
32	E4549	Joint washer	2	
33	E2980	Rocker box stud ($\frac{1}{16}$ in. O.A.)	6	
34	F879	Nut	6	
35	E3302	Plain washer	6	
36	E2982	Rocker box bolt (2 $\frac{5}{32}$ in. U.H.)	4	
37	S25-13	Plain washer	4	
38	E1596	Cylinder head bolt (for torque stay)	4	
39	E4610	Inspection cap	4	
40	E3751	Joint washer	4	
41	E4609	Locking spring	4	
42	WE170	Fibre washer	4	
43	T1553	Screw ($\frac{3}{8}$ in. U.H.)	4	
44	E1457	ROCKER (right exhaust, left inlet)	2	
45	E1458	ROCKER (left exhaust, right inlet)	2	
46	E1483	Rocker bail pin	4	
47	E1513	Rocker adjusting pin	4	
48	E470	Adjuster lock nut	4	
49	E1330	Thrust washer, $\frac{3}{8}$ in.	2	
50	E1575	Thrust washer, $\frac{1}{2}$ in.	6	
51	E1574	Spring washer	4	
52	E1512	Rocker spindle	2	
53	E3253	Sealing rubber	2	

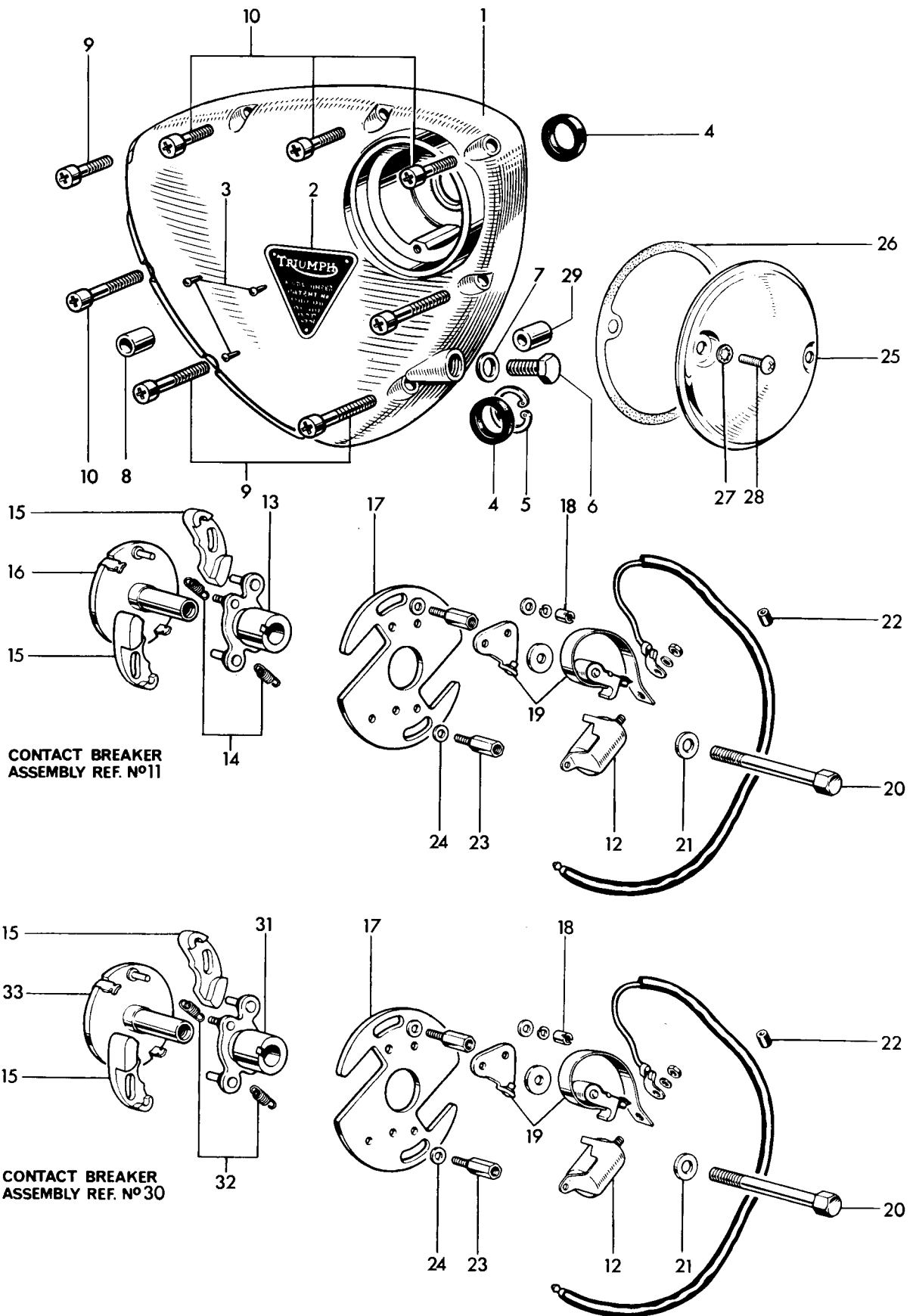

Fig. 6. TIMING COVER AND CONTACT BREAKER

TIMING COVER AND CONTACT BREAKER

1	70 E4567	Timing cover	1	
2	E4016	Patent plate	1	
3	D208-5	Hammer-drive screw	3	
4	E4568	Oil seal	2	
5	E4569	Circlip	1	
6	E2615	Timing cover plug	1	
7	E1335	Copper washer	1	
8	T989	Hollow dowel	1	
9	E3668	Screw (1 $\frac{5}{16}$ in. U.H.)	3	
10	E3204	Screw (1 in. U.H.)	5	
11	47605	CONTACT BREAKER, type 4CA	1	} Coil Ignition models
12	425377	Condenser	2	
13	54441729	Cam... ..	1	
14	54415642	Spring set	1	
15	425359	Weight	2	
16	54415751	Sleeve and action plate	1	
17	425370	Base plate	1	
18	169194	Slotted nut... ..	4	
19	54415803	Contact set	2	
20	E5451	Bolt (2 in. U.H.)	1	
21	S25-43	Plain washer	1	
22	E4707	Rubber grommet	1	
23	E4747	Pillar bolt	2	
24	E6559	Plain washer	2	
25	E4571	Cover	1	
26	E5049	Joint washer	1	
27	GS299	Serrated washer	2	
28	F4715	Screw ($\frac{1}{32}$ in. U.H.)	2	
29	E6348	Hollow metering dowel	1	
30	47602	CONTACT BREAKER, type 4CA	1	} A.C. Ignition model
12	425377	Condenser	2	
31	54415473	Cam... ..	1	
32	54415641	Spring set	1	
15	425359	Weight	2	
33	54415747	Sleeve and action plate	1	
17	425370	Base plate	1	
18	169194	Slotted nut... ..	4	
19	54415803	Contact set	2	

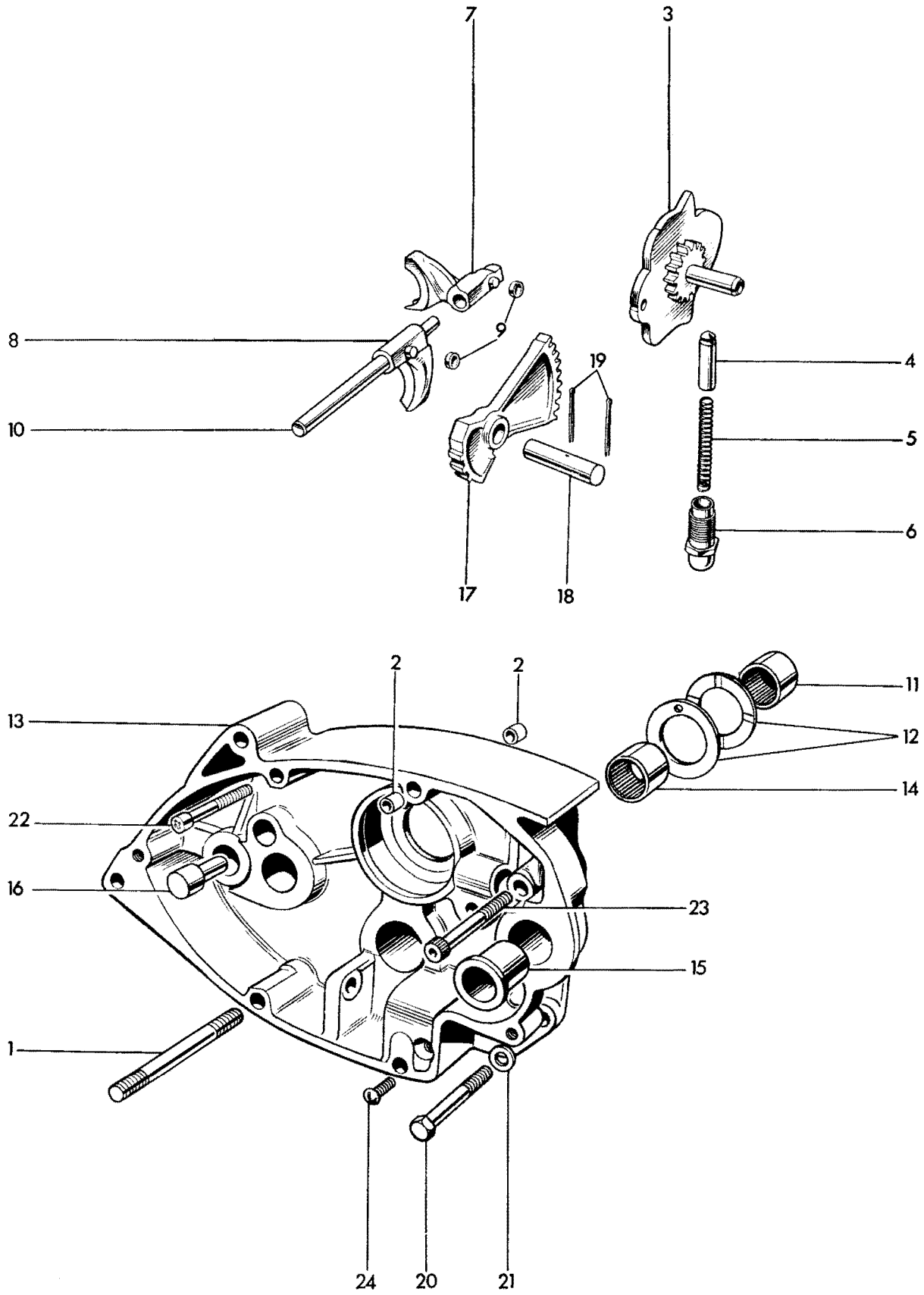

Fig. 7. GEARBOX INNER COVER AND SELECTORS

GEARBOX INNER COVER AND SELECTORS

1	E4535	Stud (3 in. O.A.)	2	
2	T989	Hollow dowel	4	
3	T500	Gear selector camplate	1	
4	T44	Camplate index plunger	1	
5	T373	Index plunger spring	1	
6	T372	Index plunger holder	1	
7	T260B	Mainshaft selector fork	1	
8	T913	Layshaft selector fork	1	
9	NT261	Selector fork roller	2	
10	T291	Selector fork rod	1	
11	T1606	Layshaft bearing	1	
12	T1607	Thrust washer	2	
13	T2112	GEARBOX INNER COVER	1	
14	T1614	Layshaft bearing	1	
15	T412	Gearchange spindle bush...	1	
16	T45	Kickstarter stop	1	
17	T397	Camplate operating quadrant...	1	
18	T1896	Quadrant spindle	1	
19	$\frac{5}{64}$ in. x $1\frac{3}{8}$ in.	Split pin	2	
20	T1778	Bolt ($1\frac{1}{8}$ in. U.H.)	1	
21	E3446	Plain washer	1	
22	E3204	Screw (1 in. U.H.)	1	
23	T1779	Socket screw ($1\frac{3}{4}$ in. U.H.)	1	
24	E3728	Countersunk screw ($\frac{1}{2}$ in. U.H.)	1	

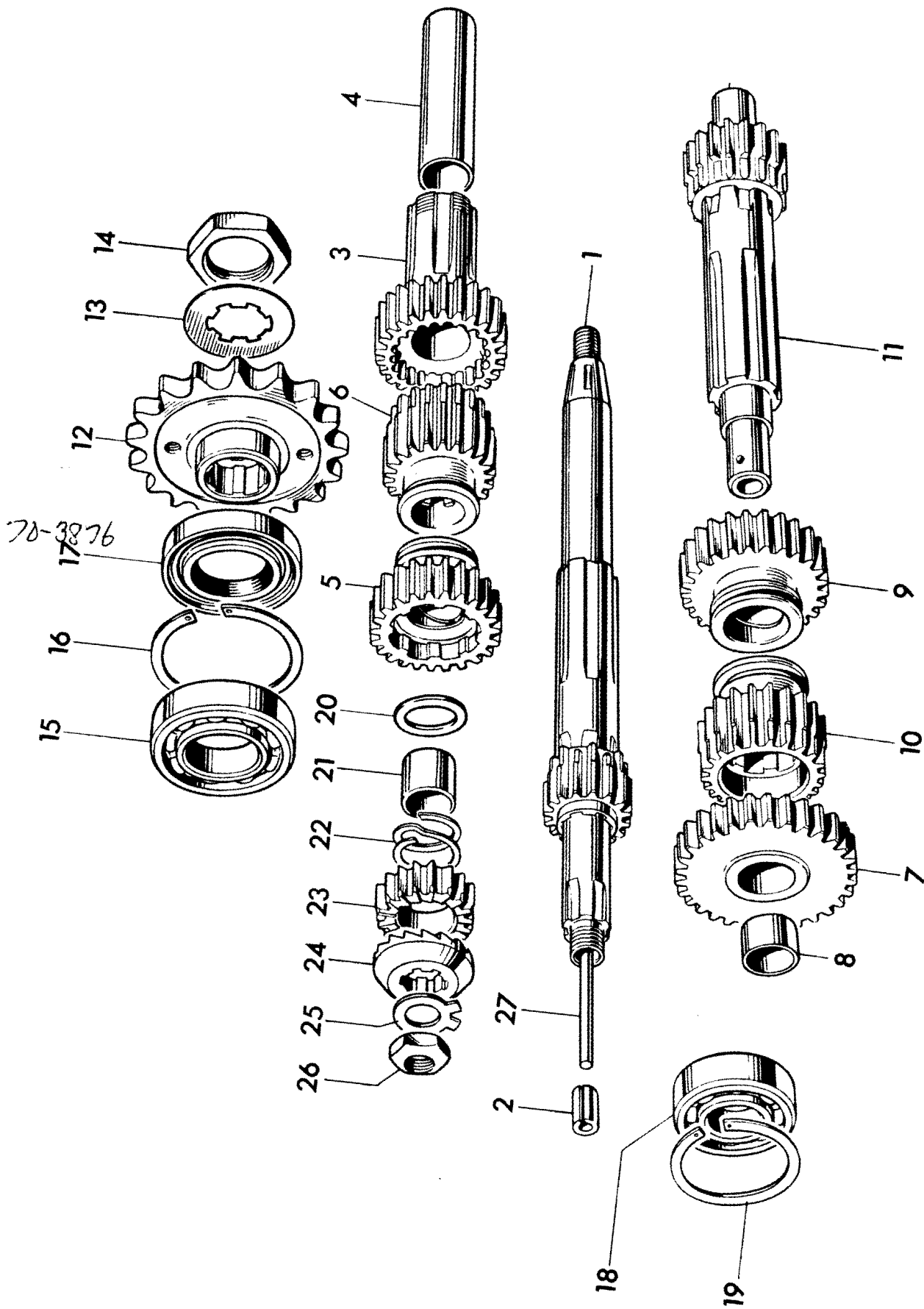

Fig. 8. GEARBOX SHAFTS AND GEARS

GEARBOX SHAFTS AND GEARS

1	T914	MAINSHAFT c/w LOW GEAR (16T)	1	
2	PT108B	Clutch rod bush	1	
3	T1914	MAINSHAFT HIGH GEAR (26T)	1	
4	T1370	High gear bush	1	
5	T917	Mainshaft third gear (24T)	1	
6	T916	Mainshaft second gear (20T)	1	
7	T926	LAYSHAFT LOW GEAR (30T)	1	
8	T928	Low gear bush	1	
9	T1065	Layshaft second gear (26T)	1	
10	T930	Layshaft third gear (22T)	1	
11	T1843	Layshaft c/w high gear (20T)	1	
12	T1952	Gearbox sprocket (15 teeth)	1	
12	T1953	Gearbox sprocket (16 teeth)	1	
12	T1916	Gearbox sprocket (17 teeth)	1	} See pages 7 to 15 for standard sizes
12	T1917	Gearbox sprocket (18 teeth)	1	
12	T1918	Gearbox sprocket (19 teeth)	1	
12	T1919	Gearbox sprocket (20 teeth)	1	
13	T2116	Tab washer	1	
14	T440	Gearbox sprocket nut	1	
15	T448	High gear bearing	1	
16	T489	Circlip	1	
17	T946	Oil seal	1	
18	S35-7	Mainshaft bearing	1	
19	T280	Circlip	1	
20	T1962	Plain washer	1	
21	T1963	Pinion sleeve	1	
22	T1250	Pinion spring	1	
23	T730	Kickstarter pinion	1	
24	T731	Kickstarter ratchet	1	
25	T732	Tab washer	1	
26	NT297	Nut	1	
27	T1736	Clutch operating rod	1	

WIDE RATIO GEARS

3	T1912	MAINSHAFT HIGH GEAR (28T)	1	} Standard on Eastern TR6C
6	T968	Mainshaft second gear (19T)	1	
9	T974	Layshaft second gear (27T)	1	
11	T1844	Layshaft c/w high gear (18T)	1	

CLOSE RATIO GEARS

1	T1177	MAINSHAFT c/w LOW GEAR (18T)	1
3	T1910	MAINSHAFT HIGH GEAR (24T)	1
5	T1179	Mainshaft third gear (23T)	1
6	T955	Mainshaft second gear (21T)	1
7	T961	LAYSHAFT LOW GEAR (28T)	1
9	T963	Layshaft second gear (25T)	1
10	T964	Layshaft third gear (23T)	1
11	T1845	Layshaft c/w high gear (22T)	1

GEARBOX OUTER COVER

1	T1986	GEARBOX OUTER COVER	1	
2	T57	Gearchange spindle bush...	1	
3	T23	Kickstarter spindle bush	1	
4	T47	Kickstarter spring anchor pin	1	
5	T454	Guide plate stud ($\frac{7}{8}$ in. O.A.)	4	
6	T1956	Oil seal	1	
7	T1955	Oil seal housing	1	
8	T408/9	Gearchange quadrant	1	
9	E3309	Rubber "O" ring	1	
10	T404	Quadrant return spring	2	
11	T406	Gearchange quadrant plunger	2	
12	T405	Plunger spring	2	
13	T407	Guide plate	1	
14	E1612	Serrated washer	4	
15	F879	Nut	4	
16	T25A	Kickstarter quadrant	1	
17	T31	Kickstarter return spring	1	
18	T24A	Kickstarter axle	1	
19	T1707	CLUTCH LEVER ASSEMBLY	1	
20	T1708	Clutch lever	1	
21	T1710	Lever shaft	1	
22	T1771	Ball, $\frac{3}{8}$ in. diam.	3	
23	T1711	Thrust plate	1	
24	T1712	Return spring	1	
25	GS127	Plain washer	1	
26	$\frac{5}{64}$ in. x $\frac{1}{2}$ in.	Split pin	1	
27	T1713	Countersunk screw ($\frac{3}{8}$ in. O.A.)	2	
28	T1714	Spoke	1	
29	T1937	Locknut	1	
30	T1946	Connector	1	
31	T1644	Abutment	1	
32	T2062	Adaptor, short		as required
32	T2063	Adaptor, long (For cable with short outer cover.)		as required
33	T1646	Rubber cover	1	
34	S25-3	Plain washer	2	
35	S1-51	Nut	1	
36	E3802	Screw ($2\frac{3}{4}$ in. U.H.)	2	
37	E3668	Screw ($1\frac{5}{8}$ in. U.H.)	2	
38	E3204	Screw (1 in. U.H.)	1	
39	T1750	Gearchange pedal	1	
40	W932	Bolt (1 in. U.H.)	1	
41	T449	Pedal rubber	1	
42	T2113	FOLDING KICKSTARTER	1	
43	T2095	Kickstarter lever	2	
44	T1272	Kickstarter pedal	1	
45	T1167	Pedal locating spring	1	
46	S70-3	Steel ball, $\frac{1}{4}$ in. diam.	1	
47	T1273	Pedal bolt	1	
48	F1814	Pedal rubber	1	
49	T1222	Cotter pin c/w nut and washer	1	
50	H1531	Domed nut	1	

CLUTCH ASSEMBLY NO 1

38

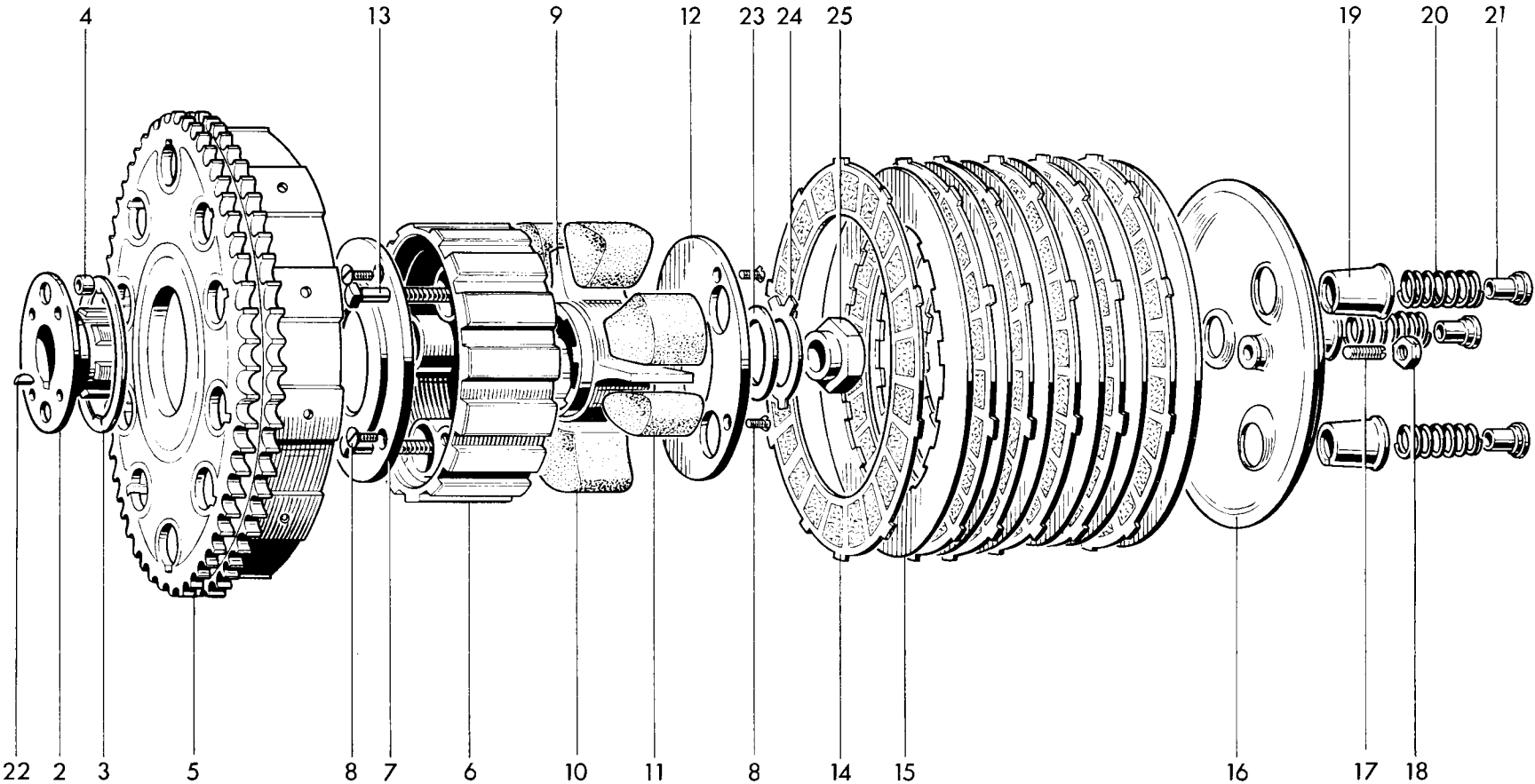

Fig. 10. CLUTCH

CLUTCH

1	T1928	CLUTCH COMPLETE	1	
2	T1734	Hub	1	
3	T1735	Thrust washer	1	
4	T394	Roller	20	
5	T1570	Sprocket and housing (58 teeth Duplex)	1	
6	T1719	Centre	1	
7	T1720	Inner plate	1	
8	T1040	Countersunk screw (0.417 in. U.H.)	6	
9	T1721	Shock absorber spider	1	
10	T1722	Drive rubber (large)	3	
11	T1723	Rebound rubber (small)	3	
12	T1724	Outer plate	1	
13	T423A	Screwed pin (1 $\frac{3}{8}$ in. U.H.)	3	
14	T1362	Driving plate (bonded)	6	
15	T1363	Driven plate	6	
16	T2156	Pressure plate	1	
17	T2159	Adjuster pin	1	
18	13206/00/1	Nut	1	
19	T1931	Spring cup	3	
20	T1830	Spring	3	
21	T427	Brass nut	3	
22	S66-1	Key	1	
23	T1045	Cupped washer	1	
24	T1046	Tab washer	1	
25	T1047	Clutch securing nut	1	

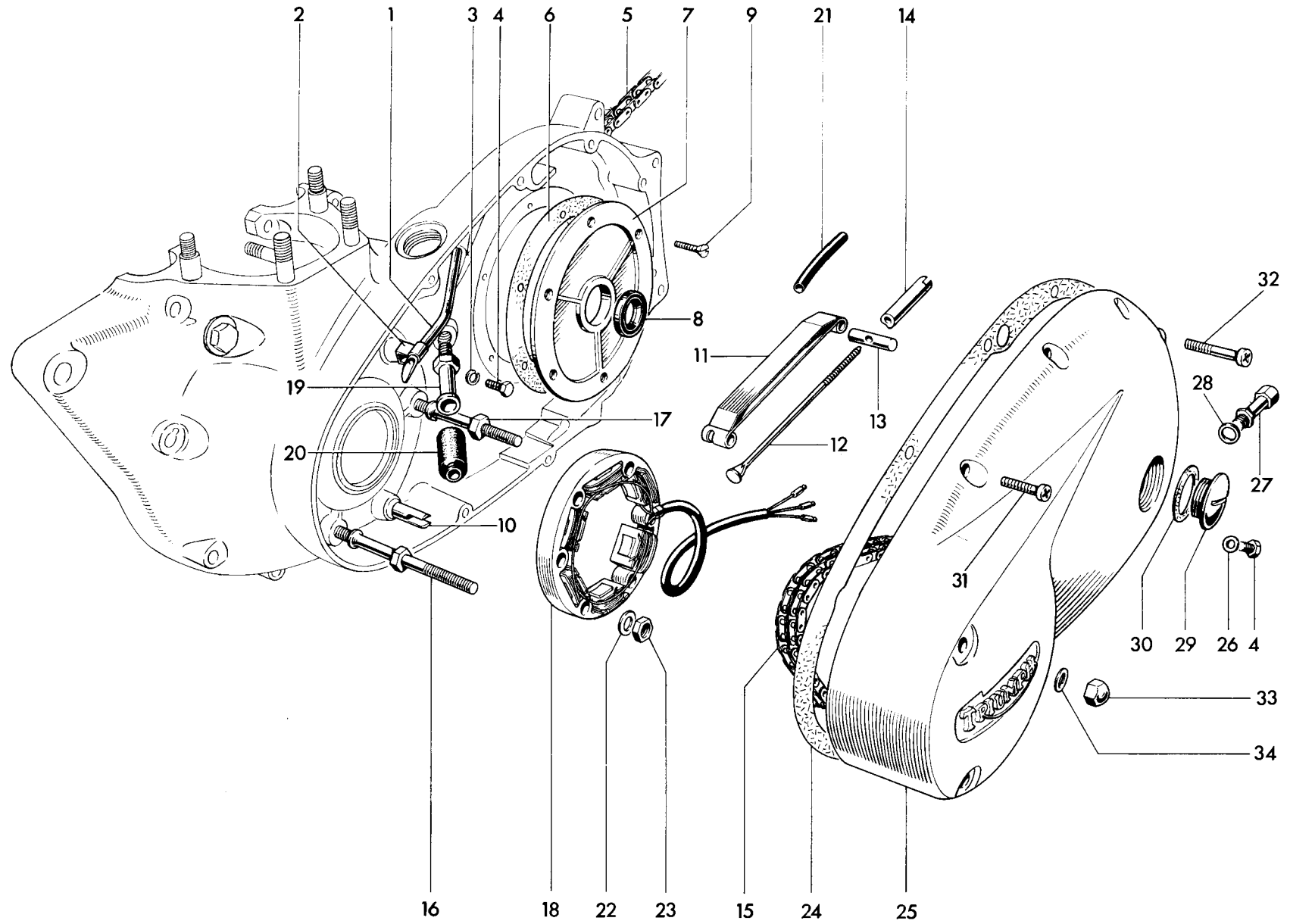

Fig. 11. CHAINCASE AND CHAINS

CHAINCASE AND CHAINS

1	E4704	Primary chain oiler tube	1	
2	E4705	Clip	1	
3	S26-2	Spring washer	1	
4	DS57	Bolt ($\frac{7}{16}$ in. U.H.)	2	
5	D444	Rear chain, $\frac{5}{8}$ in. x $\frac{3}{8}$ in. x 102 links	1	6T, TR6C (Western) & T120TT
5	D481	Rear chain, $\frac{5}{8}$ in. x $\frac{3}{8}$ in. x 103 links	1	
6	E3832	Joint washer	1	
7	E4577	Cover plate	1	
8	E4578	Oil seal	1	
9	E3821	Countersunk screw ($\frac{5}{16}$ in. U.H.)	6	
10	E5976	Chain tensioner abutment	1	
11	E6061 <i>70-6061</i>	Chain tensioner blade	1	
12	E4152	Tie rod	1	
13	E5977	Trunnion	1	
14	E4153	Adjuster sleeve nut	1	
15	D477	Primary chain, $\frac{3}{8}$ in. Duplex x 84 links	1	
16	E4536	Stator stud	2	
17	E4537	Stator stud	1	
18	47162	Stator, RM 19	1	Coil Ignition A.C. Ignition
18	47188	Stator, RM 19	1	
19	E5872	Sleeve nut	1	
20	E4144	Rubber grommet	1	
21	E5449	Plastic sleeve	1	
22	S25-3	Plain washer	3	
23	E5324	Self-locking nut	3	
24	T1770	Joint washer	1	
25	T1727	Chaincase	1	
26	E2441	Copper washer	1	
27	E6347	Drain and adjuster plug	1	
28	T1738	Fibre washer	1	
29	E732	Filler plug	1	
30	NE507	Fibre washer	1	
31	E3204	Screw (1 in. U.H.)	6	
32	E4806	Screw ($\frac{29}{32}$ in. U.H.)	2	
33	H1531	Domed nut	2	
34	F1880	Copper washer	2	

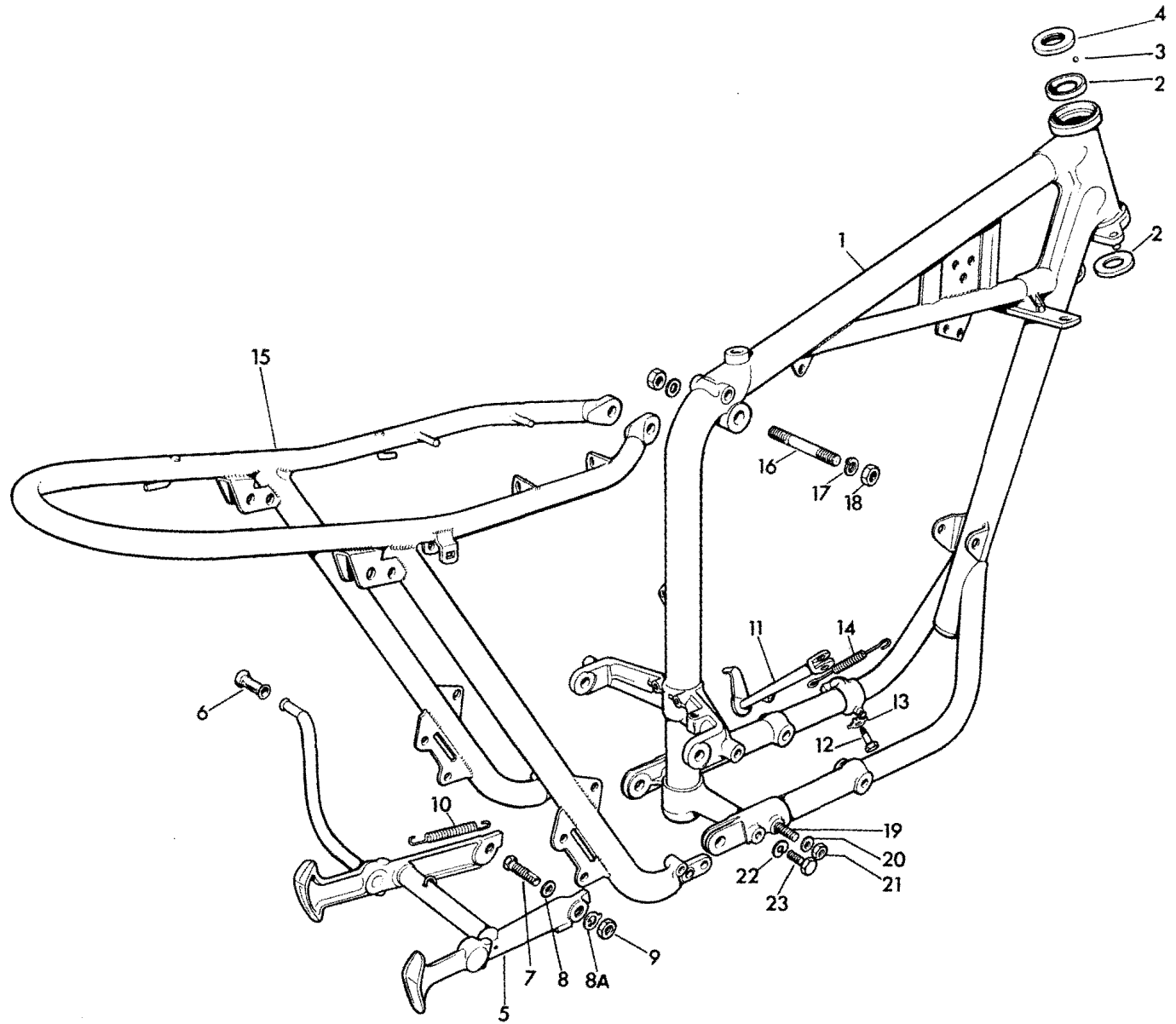

Fig. 12. FRAME

Ref. No.	Part No.	DESCRIPTION	QUANTITY	REMARKS
----------	----------	-------------	----------	---------

FRAME

1	F6903	Front frame	1	
2	H111	Steering race cup	2	
3	S70-3	Steel ball ($\frac{1}{4}$ in. diam.)	40	
4	H1018	Top cone and dust cover	1	
5	F5928	Centre stand	1	6T, T120
5	F5932	Centre stand	1	} TR6 and all U.S.A. Models
6	T449	Pedal rubber	1	
7	F5678	Pivot bolt	2	
8	F5679	Plain washer	2	
8A	F4484	Tab washer	2	
9	F2725	Nut	2	
10	F4671	Return spring	1	
11	F4388	PROP STAND COMPLETE (3.50 rear tyre)	1	
11	F6940	PROP STAND COMPLETE (4.00 rear tyre)	1	
12	F3097	Pivot bolt	1	
13	F3096	Tab washer	1	
14	F2610	Return spring	1	
15	F6904	Rear frame	1	
16	F2842	Stud ($3\frac{7}{8}$ in. O.A.)	1	
17	S26-1	Spring washer	2	
18	S1-52	Nut	2	
19	F4369	Bolt ($2\frac{1}{8}$ in. U.H.)	2	
20	F4370	Plain washer	2	
21	DS47	Nut	2	
22	PCW73A	Spring washer	2	
23	F5605	Bolt ($1\frac{3}{16}$ in. U.H.)	2	

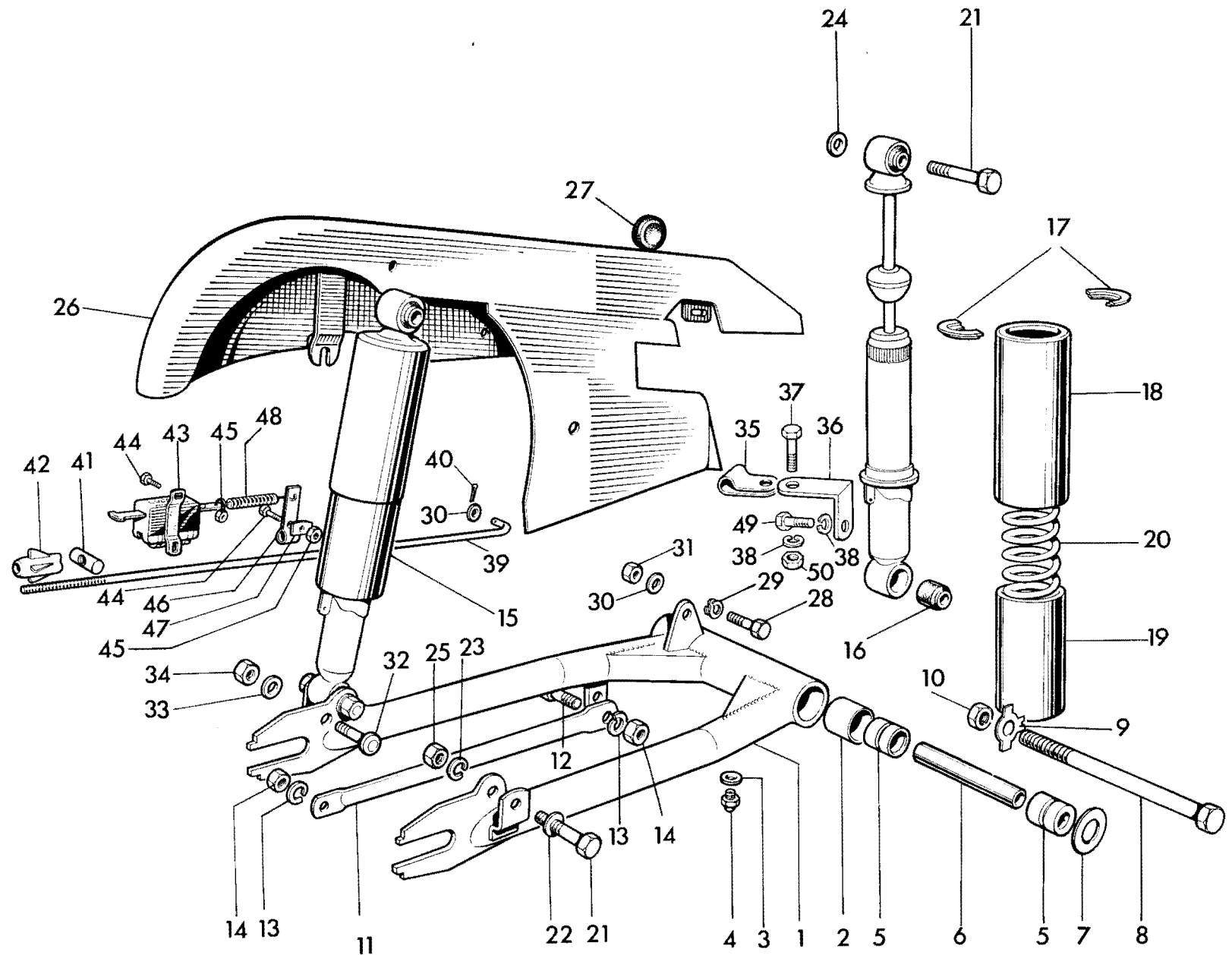

Fig. 13. SWINGING FORK AND SUSPENSION UNITS

Ref. No.	Part No.	DESCRIPTION	QUANTITY	REMARKS
SWINGING FORK AND SUSPENSION UNITS				
1	F6933	SWINGING FORK	1	
2	F6042	Pivot bush	2	
3	NW100	Grease nipple	1	
4	WE170	Fibre washer	1	
5	F6821	Sleeve	2	
6	F5313	Distance tube	1	
7	F6730	End plate	2	
8	F6150	Bolt ($8\frac{5}{8}$ in. U.H.)	1	
9	F5944	Tab washer	1	
10	NT297	Nut	1	
11	F3774	Brake torque stay	1	
12	F5315	Bolt ($2\frac{7}{8}$ in. U.H.)	1	
13	PCW73A	Spring washer	2	
14	DS47	Nut	2	
15	†64054506	SUSPENSION UNIT	2	6T, T120
15	†64054164	SUSPENSION UNIT	2	TR6 and U.S.A. T120
16	9054/316A	Bonded bush	4	
17	9054/171	Spring retainer	4	
18	9054/151	Outer dirt shield	2	
19	9054/47	Inner dirt shield	2	
20	SA253/5	Spring, 145 lbs. Blue/Yellow	2	6T, T120
20	9054/280	Spring, 100 lbs. Green/Green	2	TR6 and U.S.A. T120
21	E2113	Unit fixing bolt ($1\frac{5}{8}$ in. U.H.)	4	
22	S25-2	Plain washer	2	
23	S26-1	Spring washer	2	
24	GS308	Plain washer	3	
25	P0172A	Nut	4	
26	F7067	Chainguard	1	
27	F5536	Grommet	1	
28	F4135	Pivot bolt	1	
29	F2277	Spring washer	1	
30	S25-13	Plain washer	2	
31	E5269	Self-locking nut	1	
32	F4136	Stepped bolt	1	
33	S25-3	Plain washer	1	
34	S1-51	Nut	1	
35	F3808	Clip	1	
36	F6663	Bracket	1	No longer used
37	F1369	Bolt ($\frac{5}{8}$ in. U.H.)	1	
38	S26-2	Spring washer	2	
39	F3597	Brake operating rod	1	
40	$\frac{1}{8}$ in. x $\frac{3}{8}$ in.	Split pin	1	
41	W11	Pivot pin	1	
42	F6070	Adjuster nut	1	
43	31437	Stop lamp switch, type 22B	1	
44	T1076	Screw ($\frac{3}{8}$ in. U.H.)	3	
45	F4717	Self locking nut	5	
46	F5412	Switch lever	1	
47	F5413	"D" washer	1	
48	315738	Spring (F.3158)	1	
49	DS57	Bolt ($\frac{7}{16}$ in. U.H.)	1	No longer used
50	F879	Nut	1	
	†SB4/275	Sidecar suspension unit		as required

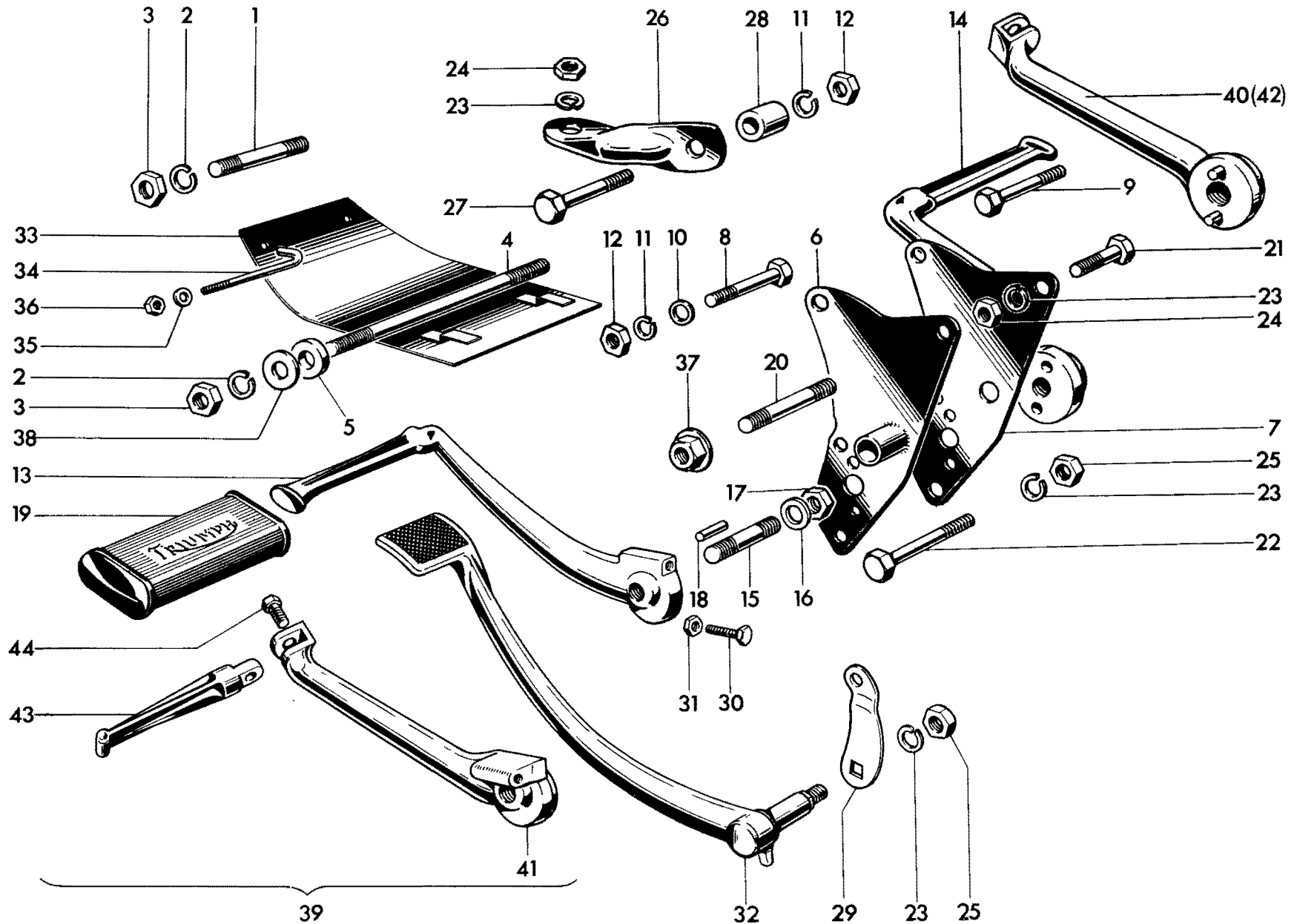

Fig. 14. ENGINE UNIT FITTING AND FOOTRESTS

ENGINE UNIT FITTINGS AND FOOTRESTS

1	F5469	Stud (3 $\frac{5}{16}$ in. O.A.)	1	
2	PCW73A	Spring washer	4	
3	DS47	Nut	4	
4	F6498	Stud (7 $\frac{7}{8}$ in. O.A.)	1	
5	F5532	Distance piece	2	
6	F6066	Left rear engine plate	1	
7	F5908	Right rear engine plate	1	
8	E4165	Bolt (1 $\frac{1}{8}$ in. U.H.)	2	
9	F5316	Bolt (1 $\frac{7}{8}$ in. U.H.)	2	
10	S25-3	Plain washer	4	
11	S26-3	Spring washer	6	
12	SI-51	Nut	6	
13	F6069	Left footrest	1	
14	F5910	Right footrest	1	
15	F5942	Stud (1 $\frac{9}{16}$ in. O.A.)	2	
16	S25-6	Plain washer	2	
17	S4-13	Nut	2	
18	F5943	Peg	4	
19	NF704	Footrest rubber	2	
20	E3114	Stud (1 $\frac{3}{8}$ in. O.A.)	2	
21	F1031	Bolt (1 $\frac{5}{16}$ in. U.H.)	1	
21	H426	Bolt (2 $\frac{3}{32}$ in. U.H.)	1	
22	F3248	Bolt (1 $\frac{1}{2}$ in. U.H.)	2	
23	S26-1	Spring washer	9	
24	S1-52	Nut	7	
25	P0172A	Nut	3	
26	E4778	Engine torque stay	4	
27	F3805	Bolt (1 $\frac{5}{16}$ in. U.H.)	2	
28	F3069	Distance piece	4	
29	F6064	Brake pedal lever	1	
30	F1149	Bolt (1 $\frac{5}{16}$ in. U.H.)	1	
31	F879	Nut	1	
32	F6449	Brake pedal	1	
33	F5472	Crankcase undershield...	1	
34	F5788	Hook bolt	2	TR6 & U.S.A. TR6C
35	S25-1	Plain washer	2	
36	F879	Nut	2	}
37	F3771	Nut	2	
38	F4370	Plain washer	2	
39	F6653	LEFT FOOTREST ASSEMBLY	1	U.S.A. TR6 & T120TT
40	F6654	RIGHT FOOTREST ASSEMBLY	1	
42	F6409	Left footrest	1	
41	F6410	Right footrest	1	
43	F6411	Footrest pedal	2	
44	F6655	Pivot bolt	2	

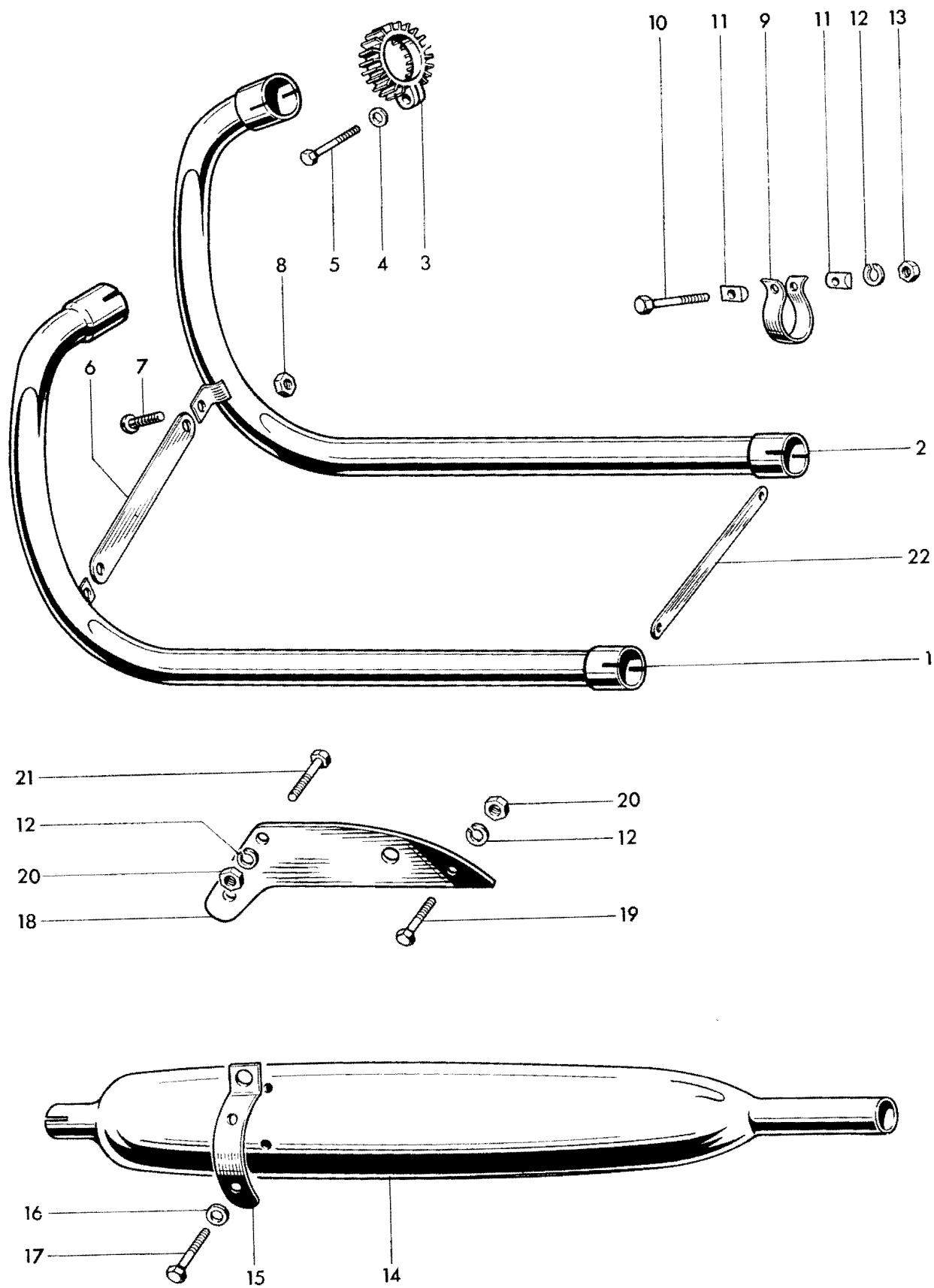

Fig. 15. EXHAUST PIPES AND SILENCERS

EXHAUST PIPES AND SILENCERS (See also Page 50)

1	70 E5957	Left exhaust pipe	1	
2	70 E5958	Right exhaust pipe	1	
3	70 E4501	Finned clip	2	
4	E410A	Hemispherical washer	2	
5	E409	Bolt (1 $\frac{3}{8}$ in. U.H.)	2	
6	E6052	Stay	1	
7	E6179	Screw ($\frac{5}{8}$ in. U.H.)	2	
8	E3290	Self locking nut	2	
9	E2271	Clip	2	
10	F3430	Bolt (1 $\frac{3}{4}$ in. U.H.)	2	
11	E3768	"D" washer	4	
12	S26-3	Spring washer	8	
13	E1310	Nut	2	
14	E4949	Silencer	2	
14	E5866	Silencer (Muffler)	2	U.S.A. 6T, TR6R, T120R
15	E4951	Bracket	2	
16	S25-3	Plain washer	4	
17	F929	Bolt ($\frac{1}{2}$ in. U.H.)	4	
18	E4711	Pillion footrest support	2	
19	F2335	Bolt ($\frac{1}{8}$ in. U.H.)	2	
20	SI-51	Nut	6	
21	DS58	Bolt ($\frac{3}{4}$ in. U.H.)	2	
22	E5676	Stay	1	

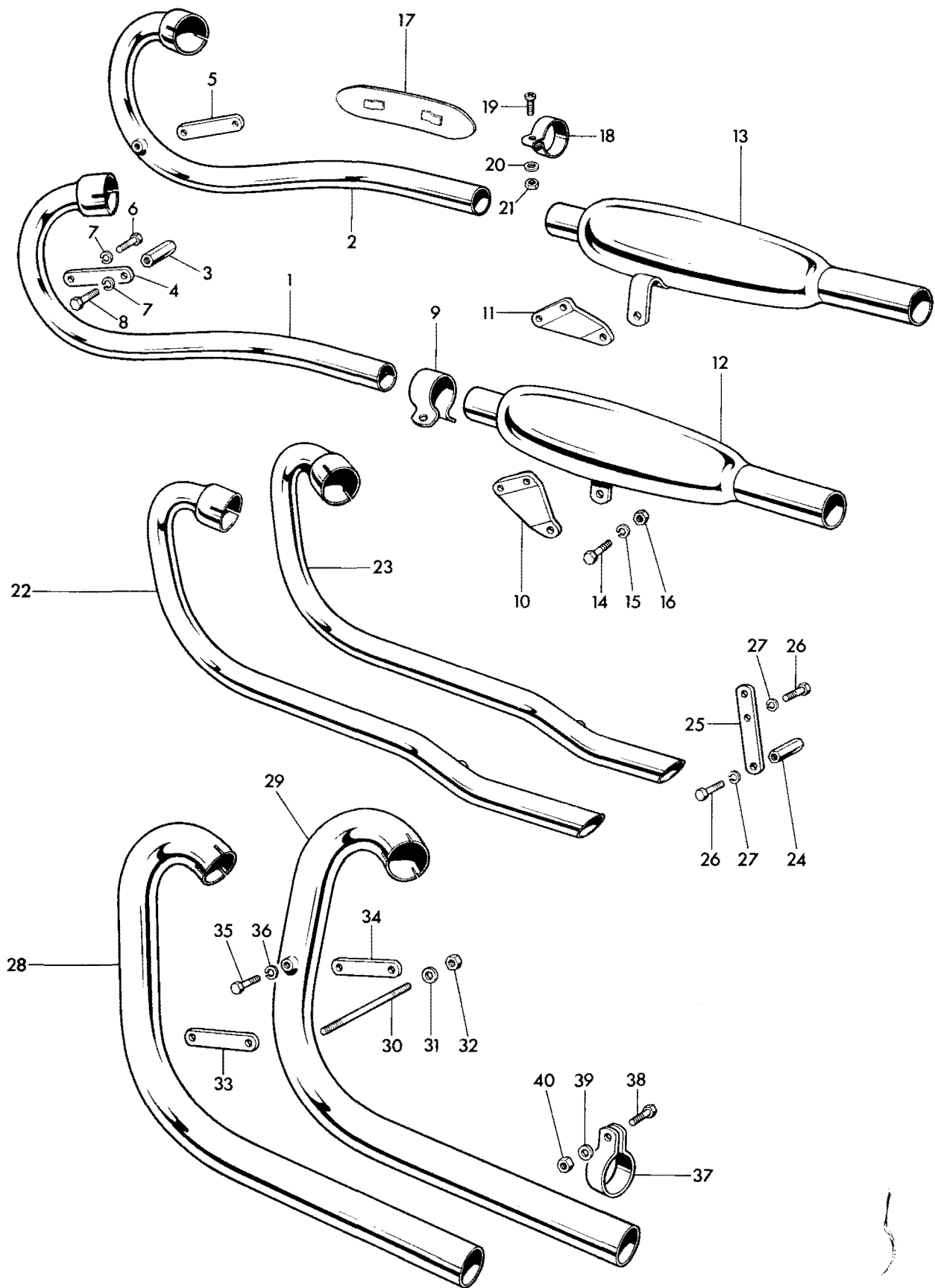

Fig. 16. EXHAUST PIPES AND MUFFLERS (U.S.A.)

EXHAUST PIPES AND MUFFLERS (U.S.A.)

1	E4884	Left exhaust pipe	1	Eastern U.S.A. TRC
2	E4886	Right exhaust pipe	1	
3	E4889	Sleeve nut	2	
4	E4887	Left stay	1	
5	E4981	Right stay	1	
6	F929	Bolt (1/2 in. U.H.)	2	
7	S26-3	Spring washer	4	
8	H590	Bolt (9/16 in. U.H.)	2	
9	E5874	Clip	2	
10	F5087	Left bracket	1	
11	F5088	Right bracket	1	
12	E4132	Left muffler	1	
13	E4176	Right muffler	1	
14	H426	Bolt (3/8 in. U.H.)	2	
15	S26-1	Spring washer	2	
16	S1-52	Nut	2	
17	E4204	Leg guard	2	
18	E4207	Clip	4	
19	F4715	Screw (1 1/2 in. U.H.)	2	
20	E2351	Plain washer	4	
21	F3799	Self-locking nut	4	
22	E6370	Left exhaust pipe	1	Western U.S.A. TR6C
23	E6372	Right exhaust pipe	1	
24	E6375	Sleeve nut	1	
25	E6374	Stay	1	
26	F929	Bolt (1/2 in. U.H.)	3	
27	S26-3	Spring washer	3	
28	E5959	Left exhaust pipe	1	T120T T
29	E5961	Right exhaust pipe	1	
30	E5963	Stud (4 3/4 in. O.A.)	1	
31	S25-3	Plain washer	2	
32	S1-51	Nut	2	
33	E5964	Left stay	1	
34	E5965	Right stay	1	
35	F929	Bolt (1/2 in. U.H.)	2	
36	S26-3	Spring washer	2	
37	E5966	Clip	2	
38	T1439	Bolt (1 3/16 in. U.H.)	2	
39	F4299	Plain washer	2	
40	S1-51	Nut	2	

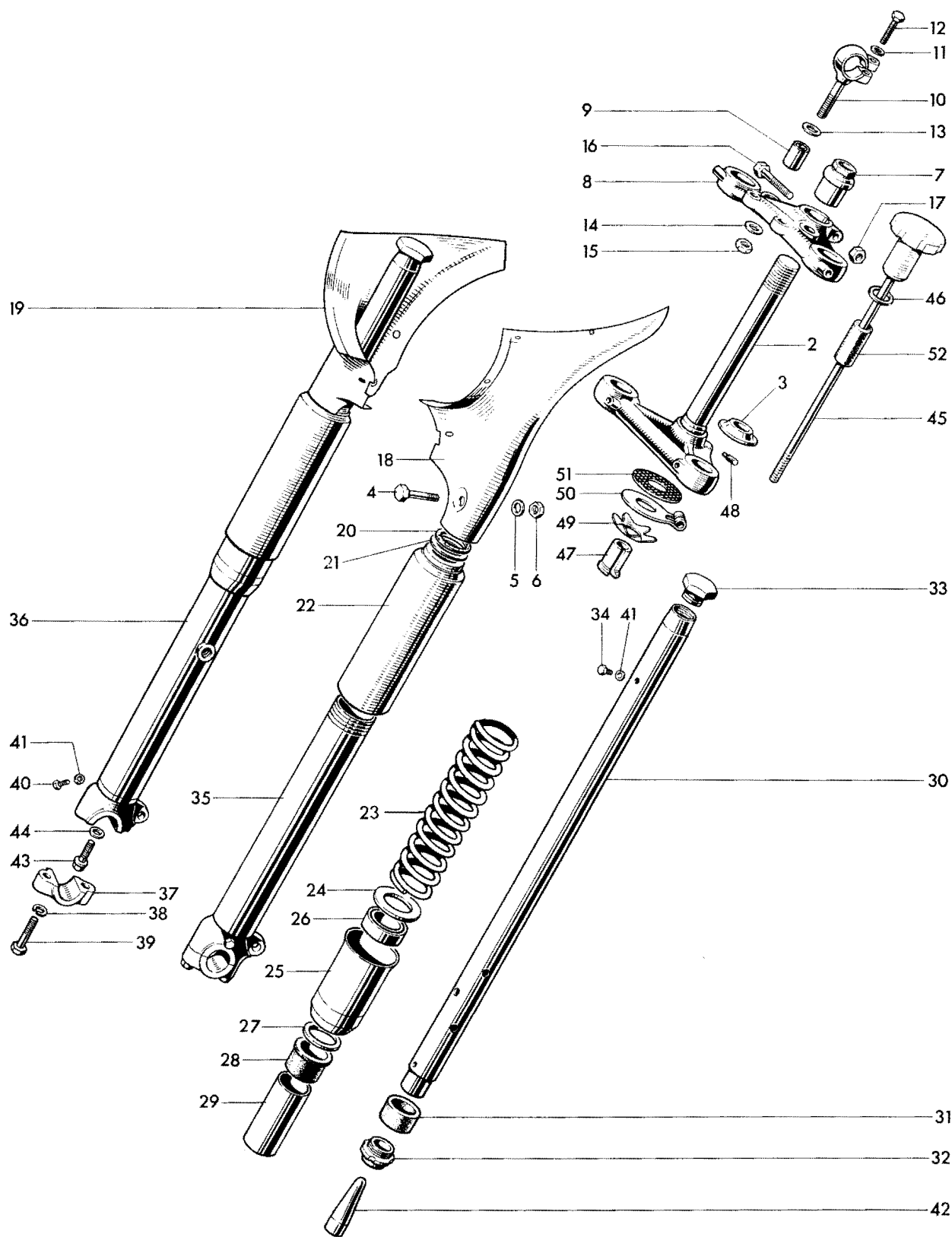

Fig. 17. TELESCOPIC FRONT FORK, 6T

Ref. No.	Part No.	DESCRIPTION	QUANTITY	REMARKS
TELESCOPIC FRONT FORK, 6T				
1	H1914	FORK ASSEMBLY	1	
2	H1577	Middle lug and stem	1	
3	H439	Bottom cone	1	
4	H941	Pinch bolt (2 $\frac{1}{4}$ in. U.H.)	2	
5	S25-2	Plain washer	2	
6	E2412	Nut	2	
7	H1141	Fork stem sleeve nut	1	
8	H1528	TOP LUG ASSEMBLY	1	
9	H1527	Bonded bush	2	
10	H1523	Handlebar eyebolt	2	
11	F1335	Plain washer	2	
12	H1340	Bolt (1 $\frac{1}{2}$ in. U.H.)	2	
13	H1708	Plain washer	2	
14	H1529	Hemispherical washer	2	
15	F3955	Self locking nut	2	
16	F1760	Pinch bolt (1 $\frac{1}{16}$ in. U.H.)	1	
17	H379	Seated nut	1	
18	H1290	Left nacelle cover	1	
19	H1291	Right nacelle cover	1	
20	F4047	Cork washer	2	
21	H1745	Plain washer	2	
22	H1916	Upper cover tube	2	
23	H1891	Solo main spring (Yellow/Blue)	2	
23	H1892	Sidecar main spring (Yellow/Green)	2	
24	H1656	Plain washer	2	
25	97- H1654	DUST EXCLUDER SLEEVE NUT	2	
26	H1500	Oil seal	2	
27	H431	Plain washer	2	
28	H441	Top bearing	2	
29	H1896	Damping sleeve	2	
30	H1890	STANCHION c/w BEARING	2	
31	H443	Lower bearing	2	
32	H1058	Bearing nut	2	
33	H1659	Cap nut	2	
34	H519A	Oil filler plug ($\frac{3}{16}$ in.)	2	
35	H1842	LEFT BOTTOM MEMBER c/w CAP	2	
36	H1843	RIGHT BOTTOM MEMBER c/w CAP	1	
37	H1844	Spindle cap	2	
38	S26-3	Spring washer	1	
39	H1070	Cap bolt (1 $\frac{7}{16}$ in. U.H.)	4	
40	H1071	Drain plug	2	
41	H430	Fibre washer	4	
42	H1499	Restrictor	2	
43	H1063	Flanged bolt ($\frac{23}{32}$ in. U.H.)	2	
44	H1062	Aluminium washer	2	
45	H1142	Steering damper rod c/w knob	1	
46	H565	Plain washer	1	
47	H408	Adjuster sleeve	1	
48	H1286	Locating pin	1	
49	H95	Spring plate	1	
50	H1797	Anchor plate	1	
51	H435	Friction disc	1	
52	H1618	Rubber sleeve	1	

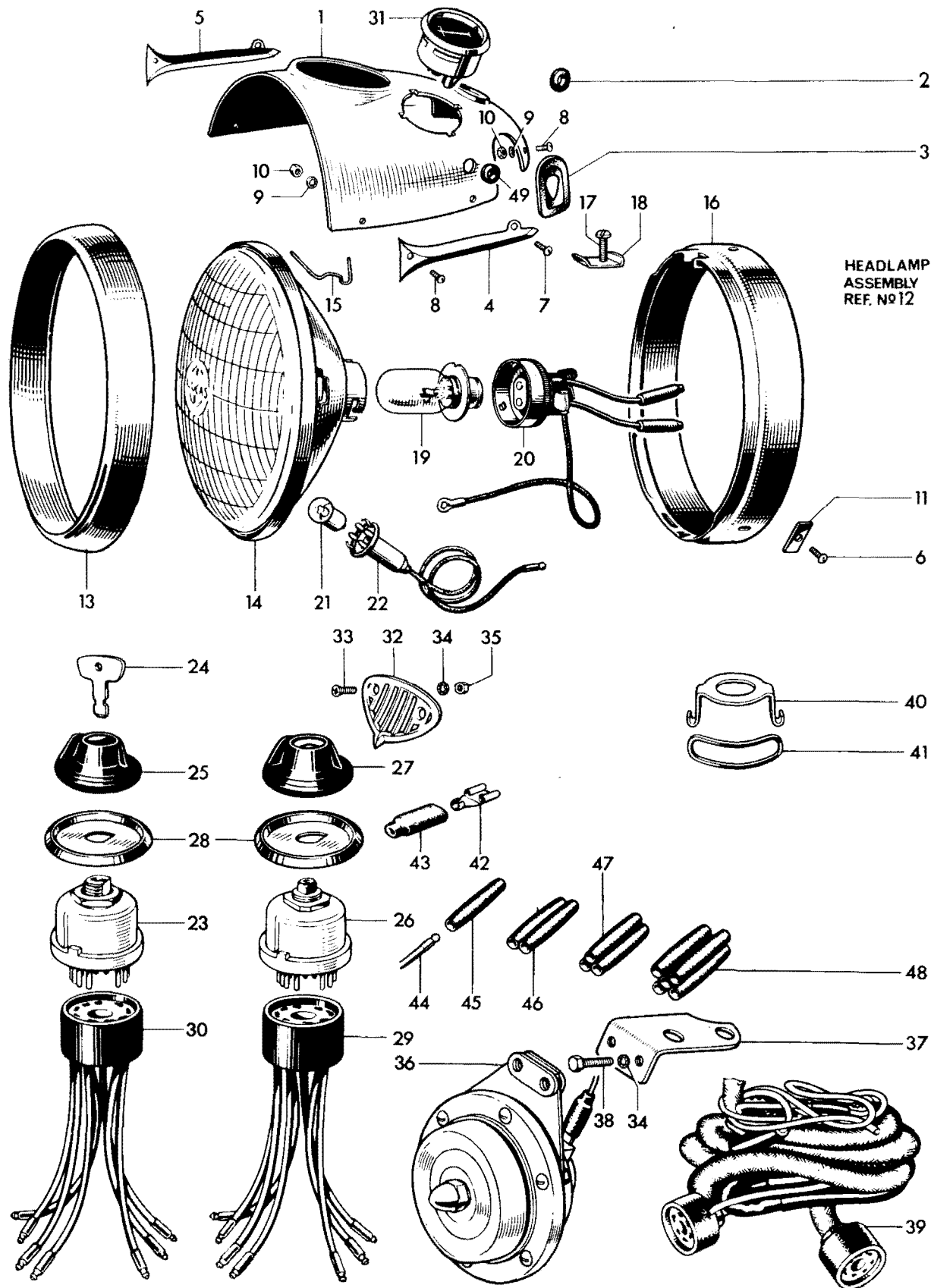

Fig. 18. NACELLE HEADLAMP AND SWITCHES

Ref. No.	Part No.	DESCRIPTION	QUANTITY	REMARKS
NACELLE HEADLAMP AND SWITCHES				
1	H1781	Nacelle top	1	
2	H1971	Plastic grommet	1	
3	H669	Rubber grommet	2	
4	H877	Left motif	1	
5	H878	Right motif	1	
6	H689	Screw ($\frac{1}{4}$ in. U.H.)	4	
7	H687	Screw ($\frac{3}{8}$ in. U.H.)	2	
8	H688	Screw ($\frac{5}{16}$ in. U.H.)	2	
9	E2880	Serrated washer	4	
10	H691	Nut	4	
11	H690	Nut	2	
12	59176	HEADLAMP	1	
13	553248	Rim	1	
14	516812	Light unit	1	
15	504665	Fixing wire... ..	6	
16	553267	Fixing ring	1	
17	144921	Screw	1	
18	534296	Plate	1	
19	414	Bulb (50/40 W. L.H. dipping. Pre-focus)	1	
20	554602	Adaptor	1	
21	222	Bulb (4W.M.C.C.)	1	
22	554710	Pilot bulbholder	1	
23	34427	IGNITION SWITCH c/w KEY, type 88SA	1	
24	54336176	Ignition key	1	
25	54336178	Ignition switch cover	1	
26	34289	Lighting switch, type 88SA	1	
27	54330934	Knob c/w screw	1	
28	54330576	Switch bezel plate	2	
29	54930007	Replacement harness socket (lighting)	A	
30	54930008	Replacement harness socket (ignition)	A	
31	36296	Ammeter, type 2AR	1	
32	H992	Horn grille	1	
33	F4129	Screw (0.435 in. U.H.)	2	
34	GS299	Serrated washer	4	
35	F3799	Nut	2	
36	H1420	Horn bracket	1	
37	70164	Horn, type 8H	1	
38	F4771	Bolt ($\frac{1}{2}$ in. U.H.)	2	
39	54938942	Wiring harness	1	
40	F5983	Bracket	2	
41	F5988	Rubber band	2	
42	54942078	Lucar connector	2	
43	54190042	Insulating cover... ..	2	
44	900269	Snap connector terminal	as required	
45	900288	Single snap connector	as required	
46	850641	Double snap connector	as required	
47	850844	Triple snap connector	as required	
48	850832	Quintuple snap connector	as required	
49	H1938	Blind grommet	2	

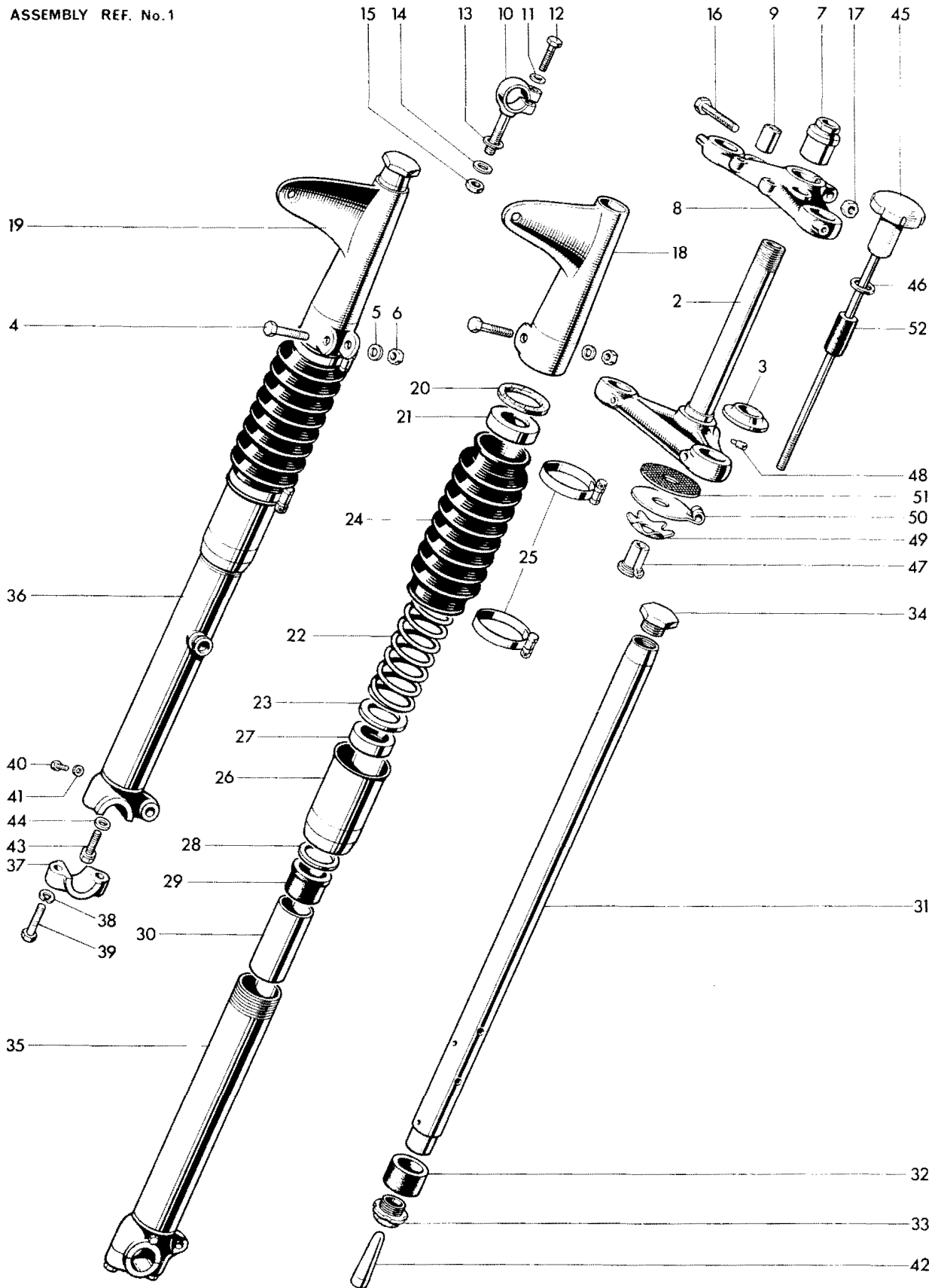

Fig. 19. TELESCOPIC FRONT FORK, TR6 AND T120

TELESCOPIC FRONT FORK, TR6 AND T120

1	H1924	FORK ASSEMBLY	1
2	H1577	Middle lug and stem	1
3	H439	Bottom cone	1
4	H941	Pinch bolt (2¼ in. U.H.)	2
5	S25-2	Plain washer	2
6	E2412	Nut	2
7	H405	Fork stem sleeve nut	1
8	H1528A	TOP LUG ASSEMBLY	2
9	H1527	Bonded bush	2
10	H1523	Handlebar eyebolt	2
11	F1335	Plain washer	2
12	H1340	Bolt (1⅛ in. U.H.)	2
13	H1708	Plain washer	2
14	H1529	Hemispherical washer	2
15	F3955	Self-locking nut	2
16	F1760	Pinch bolt (1⅞ in. U.H.)	1
17	H379	Seated nut	1
18	H1888	Left top cover	1
19	H1887	Right top cover	1
20	F4047	Cork washer	2
21	H1657	Spring abutment	2
22	H1891	Solo main spring (Yellow/Blue)	2
22	H1892	Sidocar main spring (Yellow/Green)	2
23	H1656	Plain washer	2
24	H1645	Telescopic gaiter	2
25	D340	Gaiter clip	4
26	H1654	DUST EXCLUDER SLEEVE NUT	2
27	H1500	Oil seal	2
28	H431	Plain washer	2
29	H441	Top bearing	2
30	H1896	Damping sleeve	2
31	H1889	STANCHION c/w BEARING	2
32	H443	Lower bearing	2
33	H1058	Bearing nut	2
34	H1658	Cap nut	2
35	H1842	LEFT BOTTOM MEMBER c/w CAP	1
36	H1843	RIGHT BOTTOM MEMBER c/w CAP	1
37	H1844	Spindle cap	2
38	S26-3	Spring washer	4
39	H1070	Cap bolt (1⅞ in. U.H.)	4
40	H1071	Drain plug	2
41	H430	Fibre washer	2
42	H1499	Restrictor	2
43	H1063	Flanged bolt (2⅜ in. U.H.)	2
44	H1062	Aluminium washer	2
45	H1142	Steering damper rod c/w knob	1
46	H565	Plain washer	1
47	H408	Adjuster sleeve	1
48	H1286	Locating pin	1
49	H95	Spring plate	1
50	H1797	Anchor plate	1
51	H435	Friction disc	1
52	H1618	Rubber sleeve	1

FORK ASSEMBLY REF N°1

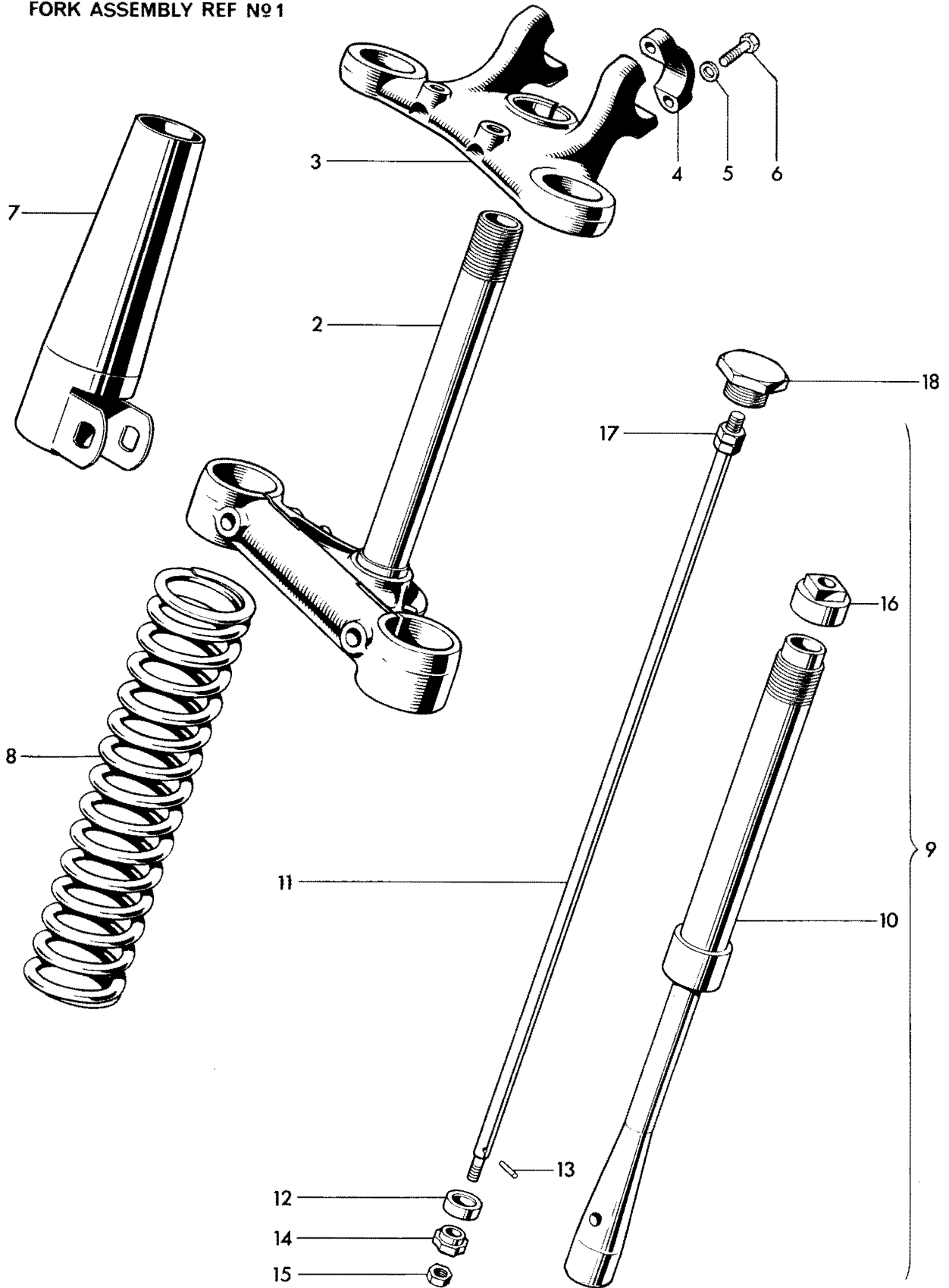

Fig. 20. TELESCOPIC FRONT FORK, U.S.A. TR6C AND T120TT

TELESCOPIC FRONT FORK, U.S.A. TR6C AND T120TT

1	H1925	FORK ASSEMBLY	1	
2	H1999	Middle lug and stem	1	
3	H1287	TOP LUG c/w CAPS	1	
4	H506	Cap	2	
5	S25-3	Plain washer	4	
6	H1340	Bolt (1 $\frac{1}{8}$ in. U.H.)	4	
7	H1696	Top cover	2	} Not Eastern TR6C
8	H1892	Main spring (yellow/green)	2	
9	H1913	DAMPER ASSEMBLY	2	
10	H1893	Restrictor body	2	
11	H1897	Rod	2	
12	H1764	Cup	2	
13	H454	Pin	2	
14	H452	Oil restrictor...	2	
15	F879	Nut	2	
16	H1761	Restrictor body cap	2	
17	T224	Nut	4	
18	H1762	Cap nut	2	

All other parts are as listed on Page 57

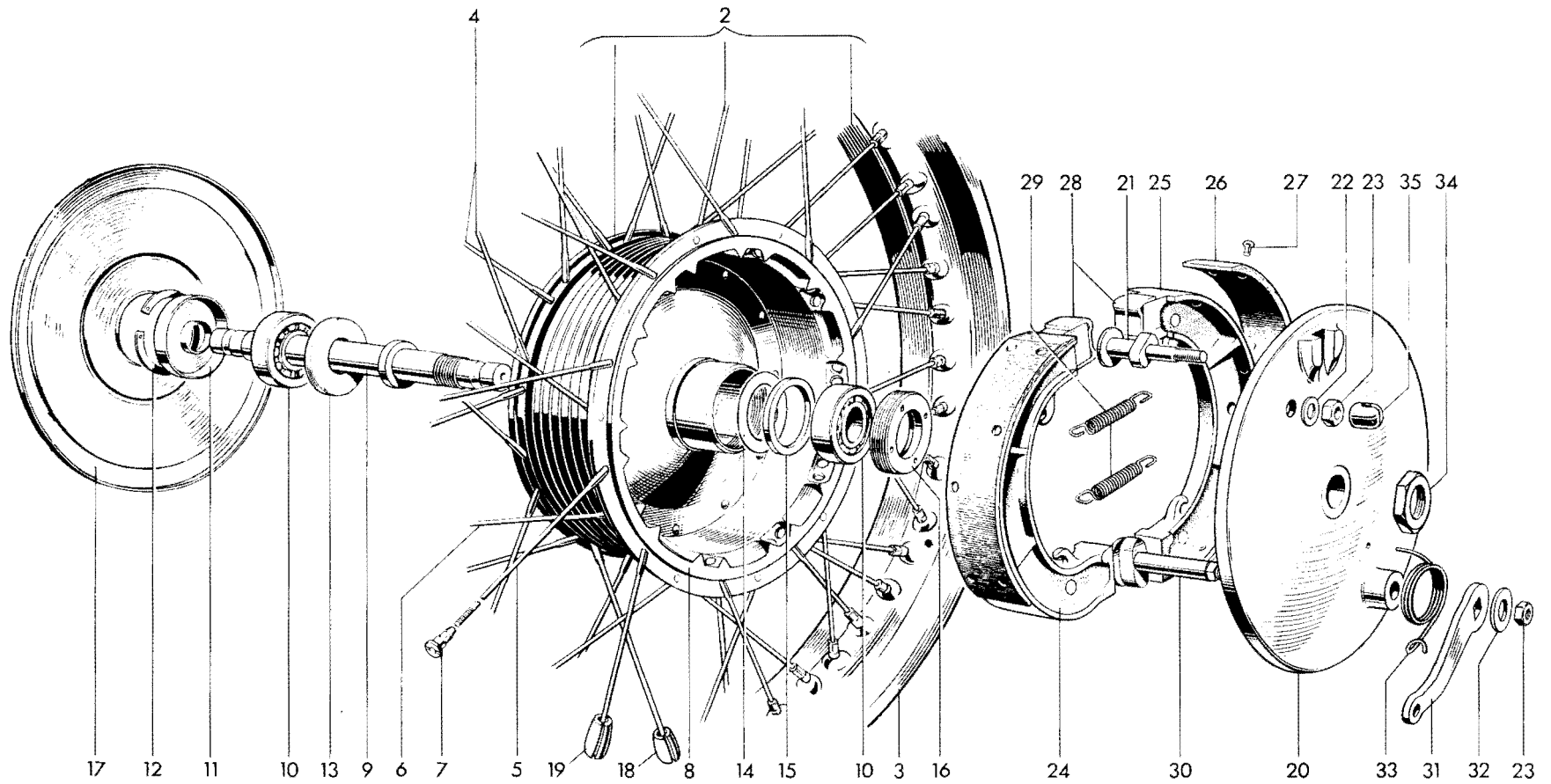

Fig. 21. FRONT WHEEL, 6T AND T120

FRONT WHEEL, 6T AND T120

1	W1739	FRONT WHEEL COMPLETE	1	
2	W1729	RIM, SPOKES AND HUB ASSEMBLY	1	
3	W1374	Front wheel rim (WM2-18)	1	
4	W1275	Spoke (8/10G x 5 $\frac{1}{8}$ in. straight) c/w nipple	20	
5	W1730	Spoke (8/10G x 4 $\frac{5}{8}$ in. 78°) c/w nipple	10	
6	W1731	Spoke (8/10G x 4 $\frac{5}{8}$ in. 100°) c/w nipple	10	
7	S79-2	Spoke nipple	40	
8	W1722	Hub and brake drum	1	
9	W1641	Wheel spindle	1	
10	W653	Bearing	2	
11	W1237	Dust cover	1	
12	T280	Circlip	1	
13	W1481	Grease retainer	1	
14	W1474	Grease retainer (brake side)	1	
15	W1238	Backing ring	1	
16	W582	Retaining ring	1	
17	W1332	Cover plate	1	
18	W1197	Balance weight, $\frac{1}{2}$ oz.		as required
19	W1198	Balance weight, 1 oz.		as required
20	W1330	Brake anchor plate	1	
21	W1639	Fulcrum pin	1	
22	S25-2	Plain washer	1	
23	S1-52	Nut	2	
24	W1732	LEADING BRAKE SHOE c/w LINING	1	
25	W1733	TRAILING BRAKE SHOE c/w LINING	1	
26	W1734	Brake lining	2	
27	W129	Brass rivet	16	
28	W1415	Pivot pad	2	
29	W135	Shoe return spring	2	
30	W1243	Brake cam	1	
31	W1331X	Brake cam lever	1	
32	S25-6	Plain washer	1	
33	W592	Lever return spring	1	
34	W1246	Anchor plate nut	1	
35	W1640	Abutment ($\frac{9}{16}$ in. deep)		as required
35	W1711	Abutment ($\frac{13}{16}$ in. deep)		as required

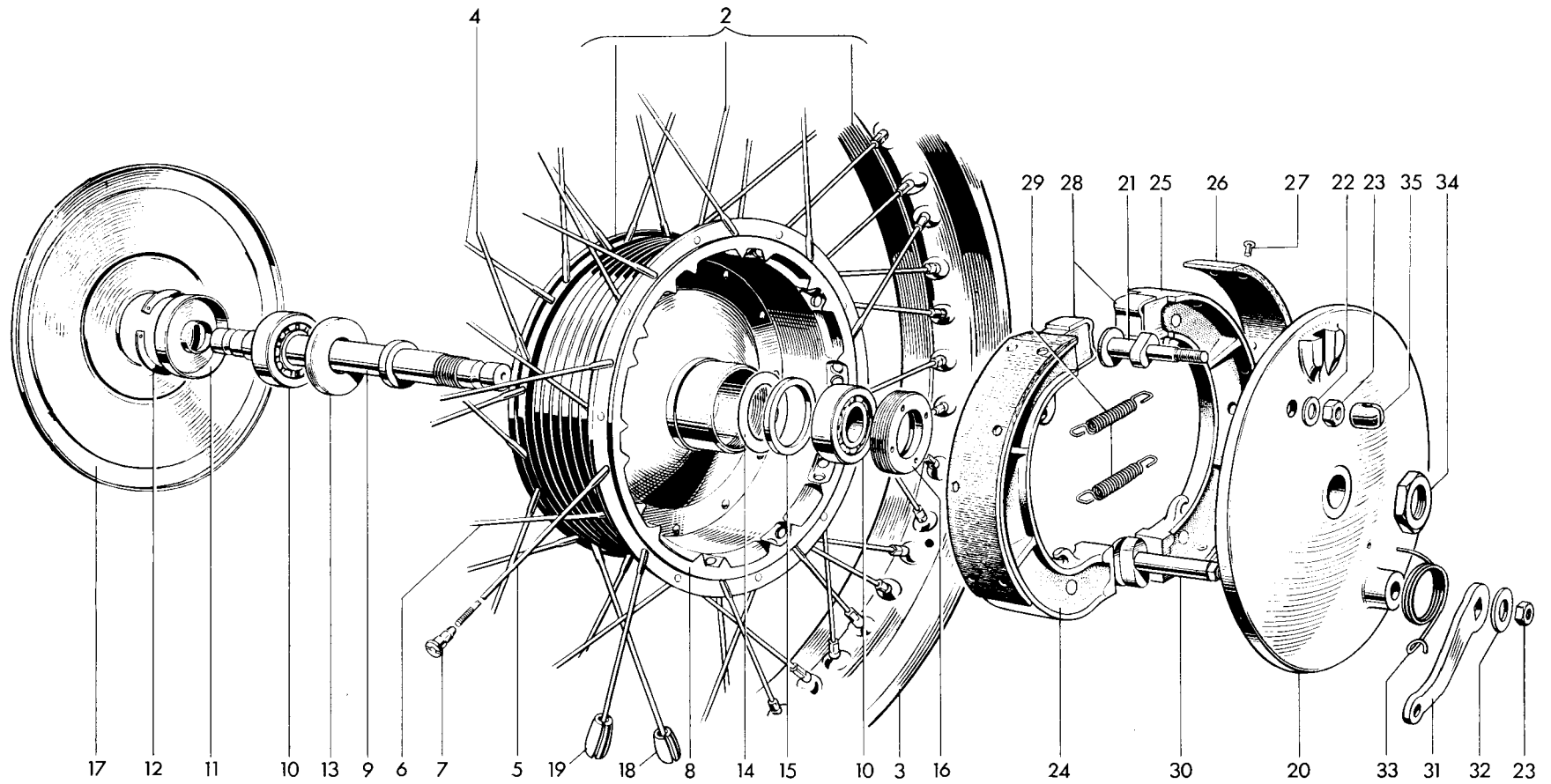

Fig. 22. FRONT WHEEL, TR6 AND U.S.A. T120

FRONT WHEEL, TR6 AND U.S.A. T120

1	W1720	FRONT WHEEL COMPLETE	1	
2	W1721	RIM, SPOKES AND HUB ASSEMBLY	1	
3	W1230	Front wheel rim (WM2-19)	1	
4	W1328	Spoke (8/10G x 5 $\frac{5}{8}$ in. straight) c/w nipple	20	
5	W1708	Spoke (8/10G x 4 $\frac{3}{4}$ in. 78°) c/w nipple	10	
6	W1709	Spoke (8/10G x 4 $\frac{7}{8}$ in. 100°) c/w nipple	10	
7	S79-2	Spoke nipple	40	
8	W1722	Hub and brake drum	1	
9	W1641	Wheel spindle	1	
10	W653	Bearing	2	
11	W1237	Dust cover	1	
12	T280	Circlip	1	
13	W1481	Grease retainer	1	
14	W1474	Grease retainer (brake side)	1	
15	W1238	Backing ring	1	
16	W582	Retaining ring	1	
17	37 W1332	Cover plate	1	
18	W1197	Balance weight, $\frac{1}{2}$ oz.	as required	
19	W1198	Balance weight, 1 oz.	as required	
20	W1330	Brake anchor plate	1	
21	W1639	Fulcrum pin	1	
22	S25-2	Plain washer	1	
23	S1-52	Nut	2	
24	W1732	LEADING BRAKE SHOE c/w LINING	1	
25	W1733	TRAILING BRAKE SHOE c/w LINING	1	
26	W1734	Brake lining	2	
27	W129	Brass rivet	16	
28	W1415	Pivot pad	2	
29	W135	Shoe return spring	2	
30	W1243	Brake cam	1	
31	W1331X	Brake cam lever	1	
32	S25-6	Plain washer	1	
33	W592	Lever return spring	1	
34	W1246	Anchor plate nut	1	
35	W1640	Abutment ($\frac{9}{16}$ in. deep)	as required	
35	W1711	Abutment ($\frac{13}{16}$ in. deep)	as required	

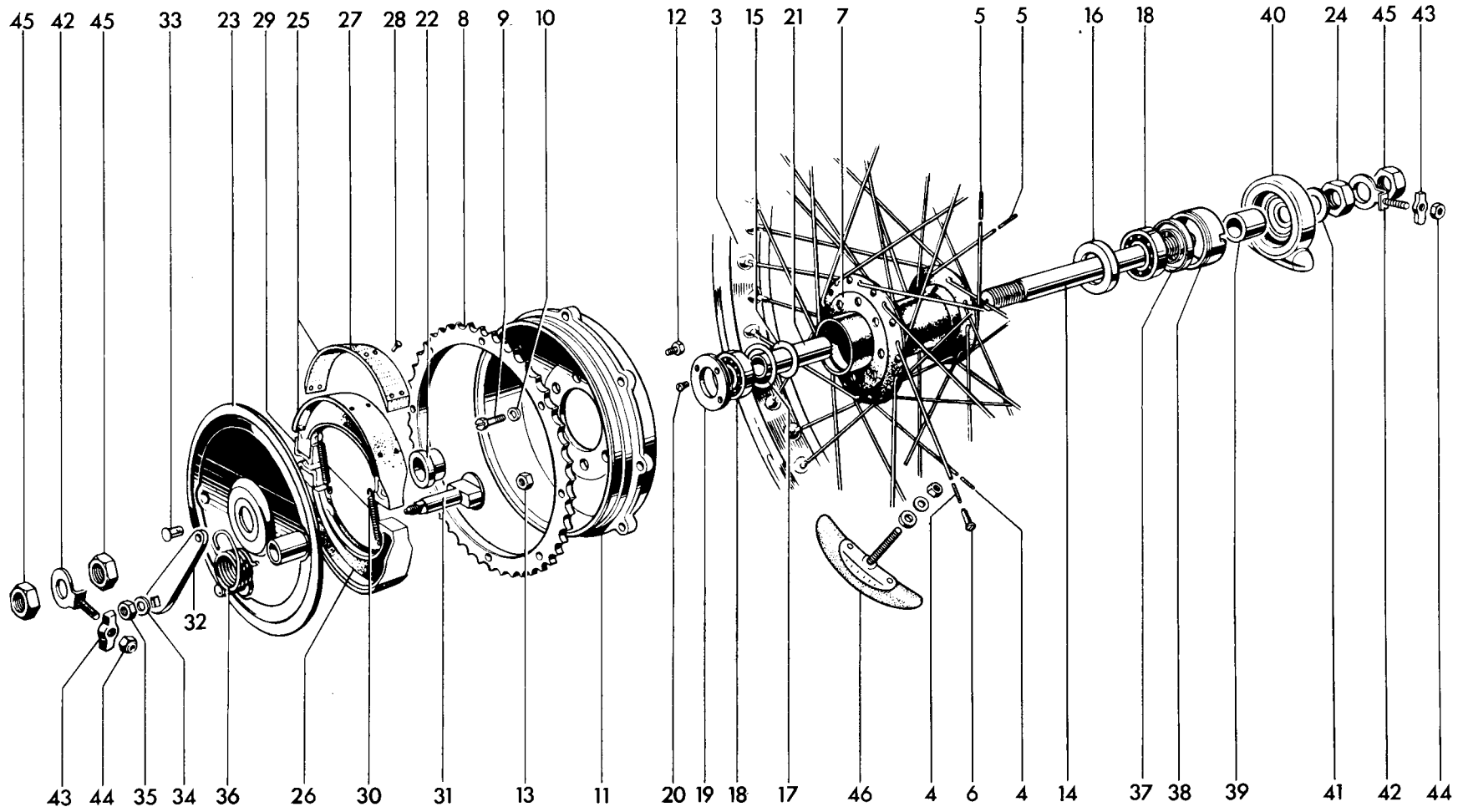

Fig. 23. REAR WHEEL

Ref. No.	Part No.	DESCRIPTION	QUANTITY	REMARKS
REAR WHEEL				
1	W1741	REAR WHEEL COMPLETE	1	6T & T120
1	W1742	REAR WHEEL COMPLETE	1	TR6 & U.S.A. T120
2	W1470	RIM, SPOKES AND HUB ASSEMBLY	1	6T & T120
2	W1486	RIM, SPOKES AND HUB ASSEMBLY	1	TR6 & U.S.A. T120
3	W1471	Rear wheel rim WM2-18	1	6T & T120
3	W1007	Rear wheel rim WM3-18	1	TR6 & U.S.A. T120
4	W1107	Spoke (8/10G x 7 ⁹ / ₁₆ in. 90°) c/w nipple	20	
5	W1108	Spoke (8/10G x 7 ⁷ / ₈ in. 90°) c/w nipple	20	
6	S79-2	Spoke nipple	40	
7	W1472	Hub	1	
8	W1499	Sprocket, 46T	1	
9	W1500	Bolt (1 ³ / ₈ in. U.H.)	8	
10	E1612	Serrated washer	8	
11	W1498	Brake drum	1	
12	W1690	Bolt (1 ¹ / ₈ in. U.H.)	8	
13	W1691	Self locking nut	8	
14	W1281	Wheel spindle	1	
15	W1474	Grease retainer (brake side)	1	
16	W1654	Grease retainer	1	
17	W1022	Backing ring	1	
18	W653	Bearing	2	
19	W1021	RETAINING RING	1	
20	W1710	Locking screw (5 ⁵ / ₁₆ in. U.H.)	1	
21	W1278	Distance tube	1	
22	W1024	Distance piece	1	
23	W1112	Brake anchor plate	1	
24	W1282	Nut	1	
25	W1406	LEADING BRAKE SHOE C/W LINING	1	
26	W1407	TRAILING BRAKE SHOE C/W LINING	1	
27	NW243	Brake lining	2	
28	W129	Brass rivet	16	
29	W1415	Thrust pad	2	
30	W135	Shoe return spring	2	
31	W1083	Brake cam	1	
32	W1466	Brake cam lever	1	
33	W1467	Pivot pin	1	
34	S25-6	Plain washer	1	
35	S1-52	Nut	1	
36	W1090	Lever return spring	1	
37	W1635	Grease retainer	1	
38	W1476	Speedometer adaptor	1	
39	W1477	Distance piece	1	
40	D373	Speedometer gearbox	1	
41	W1280	Plain washer	1	
42	W1134	Chain adjuster	2	
43	W1015	Adjuster end plate	2	
44	W1058	Self-locking nut	2	
45	F1747	Spindle nut	3	
46	D106	Tyre security bolt (WM2)	2	6T & T120
46	WM3	Tyre security bolt	2	TR6 & U.S.A. T120

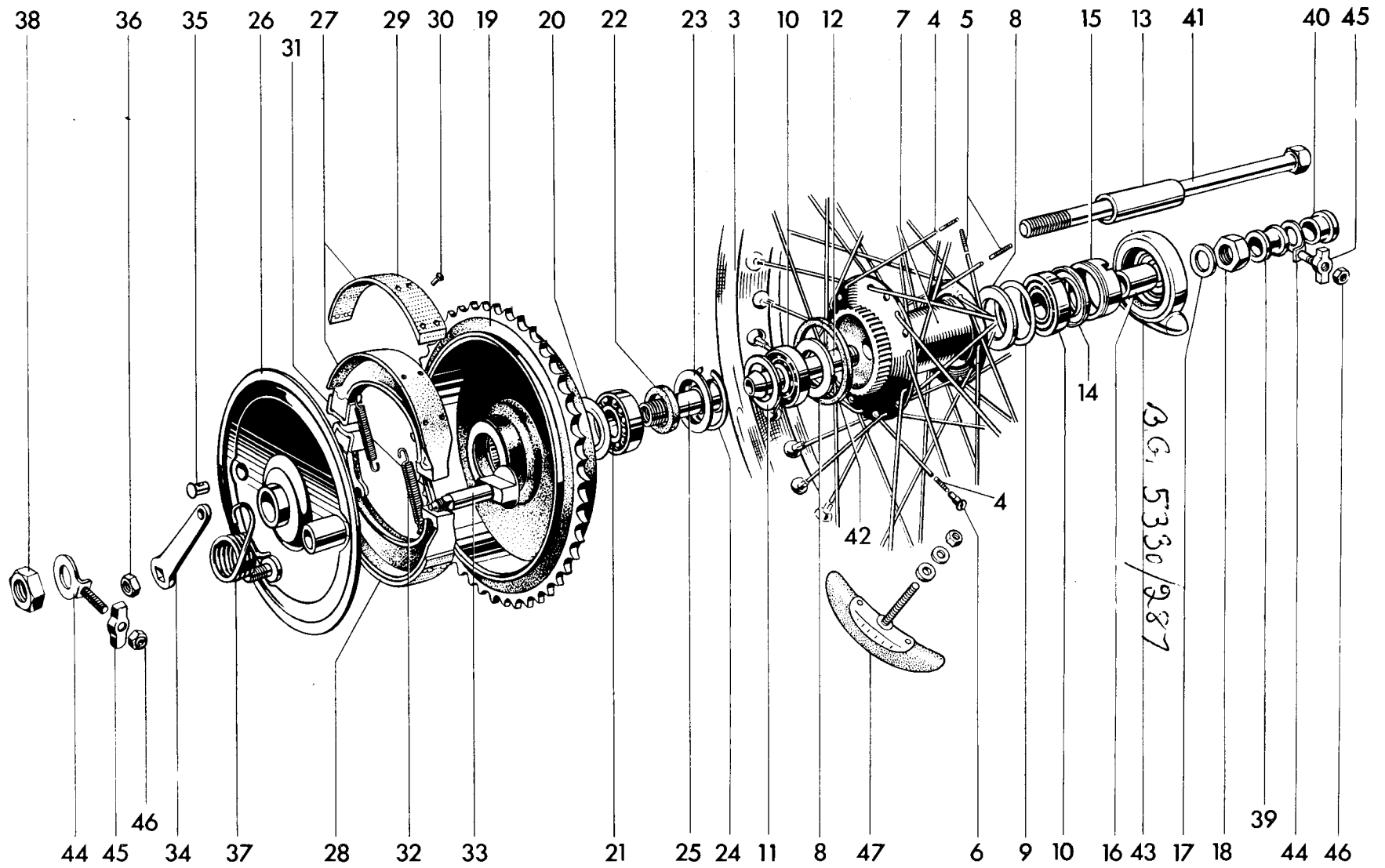

Fig. 24. QUICKLY DETACHABLE REAR WHEEL

Ref. No.	Part No.	DESCRIPTION	QUANTITY	REMARKS
QUICKLY DETACHABLE REAR WHEEL				
1	W1746	Q.D. REAR WHEEL COMPLETE	1	6T, T120
1	W1745	Q.D. REAR WHEEL COMPLETE	1	TR6, U.S.A. T120
2	W1747	RIM, SPOKES AND HUB ASSEMBLY	1	6T, T120
2	W1603	RIM, SPOKES AND HUB ASSEMBLY	1	TR6, U.S.A. T120
3	W1471	Rear wheel rim WM2-18	1	6T, T120
3	W1007	Rear wheel rim WM3-18	1	TR6, U.S.A. T120
4	W1107	Spoke (8/10 x 7 $\frac{9}{16}$ in. 90°) c/w nipple	20	
5	W1108	Spoke (8/10G x 7 $\frac{7}{8}$ in. 90°) c/w nipple	20	
6	S79-2	Spoke nipple	40	
7	W1593	Hub	1	
8	W1595	Grease retainer	2	
9	W1509	Backing ring	1	
10	S35-7	Bearing	2	
11	W1596	Dust cap	1	
12	W1614	Bearing sleeve	1	
13	W1598	Distance piece (inner)	1	
14	W1635	Grease retainer	1	
15	W1599	Locking ring	1	
16	W1477	Distance piece (outer)	1	
17	W1280	Plain washer	1	
18	W1282	Nut	1	
19	W1040	Sprocket and brake drum 46T	1	
20	W1143	Grease retainer	1	
21	W1041	Bearing	1	
22	W1042	Felt washer	1	
23	W1043	Bearing and felt retainer	1	
24	W1044	Circlip	1	
25	W1045	Bearing sleeve	1	
26	W1121	Brake anchor plate	1	
27	W1406	LEADING BRAKE SHOE C/W LINING	1	
28	W1407	TRAILING BRAKE SHOE C/W LINING	1	
29	NW243	Brake lining	2	
30	W129	Brass rivet	16	
31	W1415	Thrust pad	2	
32	W135	Shoe return spring	2	
33	W1083	Brake cam	1	
34	W1466	Brake cam lever	1	
35	W1467	Pivot pin	1	
36	S1-52	Nut	1	
37	W1090	Lever return spring	1	
38	W1052	Nut	1	
39	W1392	Inner distance piece	1	
40	W1170	Outer distance piece	1	
41	W1055	Spindle	1	
42	W1091	Rubber sealing ring	1	
43	D373	Speedometer gearbox	1	
44	W1135	Chain adjuster	2	
45	W1015	Adjuster end plate	2	
46	W1058	Self-locking nut	2	
47	D106	Tyre security bolt, WM2	2	6T, T120
47	WM3	Tyre security bolt	2	TR6, U.S.A. T120

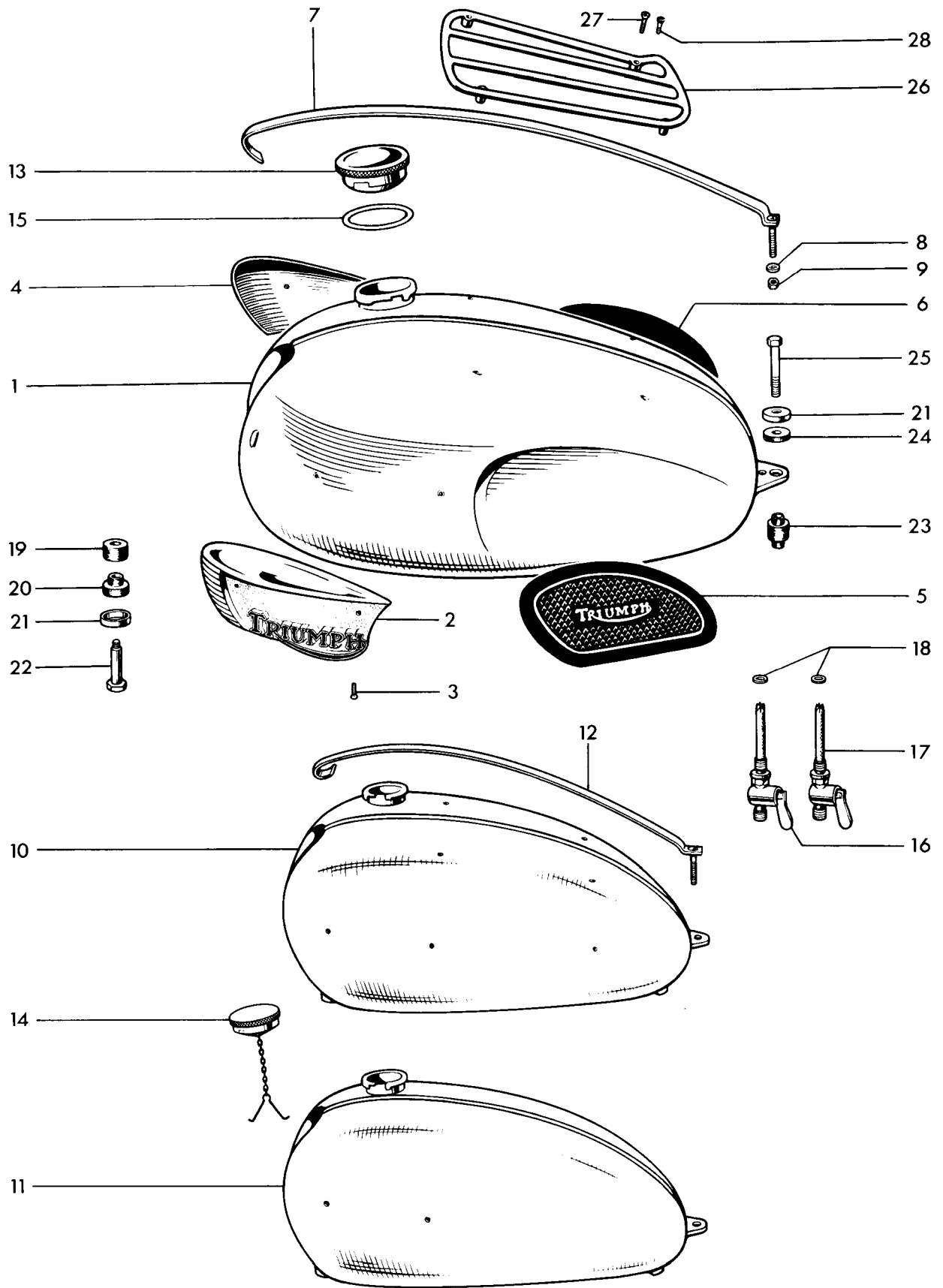

Fig. 25. PETROL (GAS) TANKS

Ref. No.	Part No.	DESCRIPTION	QUANTITY	REMARKS
PETROL (GAS) TANKS				
1	F7004	Petrol tank (4 gallons)	1	6T, TR6 & T120
2	F6887	Styling unit (left)	1	
3	F4129	Styling unit screw (0.435 in. U.H.)	4	
4	F6888	Styling unit (right)	1	
5	F5401	Left knee grip	1	
6	F5402	Right knee grip	1	
7	F5398	Centre styling strip	1	6T, TR6 & T120
8	F4019	Serrated washer	1	
9	H919	Nut	1	
10	F7003	Petrol tank (3½ gallons)	1	U.S.A. 6T, TR6R
11	F6728	Petrol tank (2½ gallons)	1	{ TR6C, T120R, T120TT U.S.A.
12	F5564	Centre styling strip	1	
13	F3220	FILLER CAP	1	
14	F3219	FILLER CAP c/w JACK CHAIN	1	TR6C, T120TT
15	F4048	Joint washer	1	
16	F4971	Petrol tap (left)... ..	1	
17	F4972	Petrol tap with reserve tube	1	
18	F1511	Fibre washer	2	
19	F5228	Rubber washer	2	
20	F5229	Spigot rubber	2	
21	F3814	Cup	3	
22	F1808	Shouldered bolt	2	
23	F5336	Double spigot rubber	1	
24	F967	Rubber washer	1	
25	F5337	Bolt (1½ in. U.H.)	1	
26	F3917	Parcel grid	1	
27	F2936	Screw	1	
28	F4384	Rubber blanking plug	A	

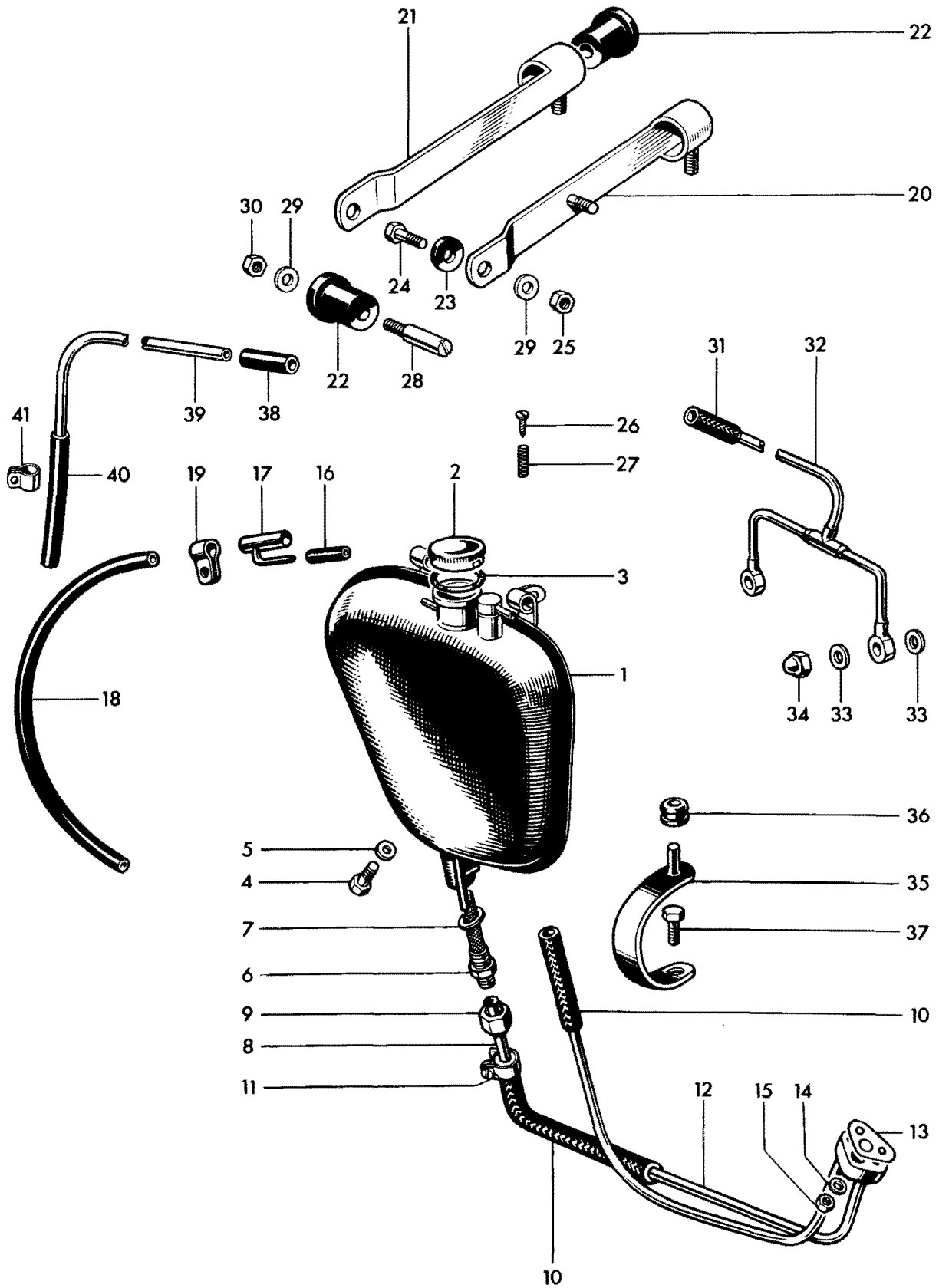

Fig. 26. OIL TANK

OIL TANK

1	F6877	Oil tank ...	1	
2	F3216	FILLER CAP ...	1	
3	F4047	Joint washer ...	1	
4	F5343	Drain plug ...	1	
5	PT104B	Fibre washer ...	1	
6	F3179	Oil tank filter ...	1	
7	F1713	Fibre washer ...	1	
8	F3655	Upper feed pipe ...	1	
9	F3182	Union nut ...	1	
10	E4594	Flexible connector ...	2	
11	E5473	Clip ...	4	
12	E4590	Oil pipes and junction block ...	1	
13	E3763	Joint washer ...	1	
14	E3446	Plain washer ...	1	
15	E1310	Nut ...	1	
16	E6356	Vent pipe ...	1	
17	E5370	"T" piece ...	1	
18	E5376	Extension pipe ...	1	
19	F3098	Clip ...	2	
20	F6892	Front strap ...	1	
21	*F6894	Rear Strap ...	1	
22	F6673	Spigot rubber ...	4	
23	F6968	Rubber washer ...	2	
24	11104/06/2	Bolt ($\frac{3}{4}$ in. U.H.) ...	2	
25	15104/00/2	Self locking nut ...	2	
26	F6511	Metering screw ...	1	
27	F6874	Coil spring ...	1	
28	F6672	Screwed peg ...	2	
29	S25-13	Plain washer ...	4	
30	F879	Nut ...	2	
31	E6353	Rubber connector ...	1	
32	E6349	Rocker oil feed pipe ...	1	
33	E1335	Copper washer ...	4	
34	E1435	Domed nut ...	2	
35	F6147	Bracket ...	1	
36	F6039	Grommet ...	1	
37	F929	Bolt ($\frac{1}{2}$ in. U.H.) ...	1	
38	E6355	Flexible pipe ...	1	
39	E6354	Chain oiler pipe ...	1	
40	E6357	Flexible pipe ...	1	
41	F6970	Clip ...	1	

* See Page 73

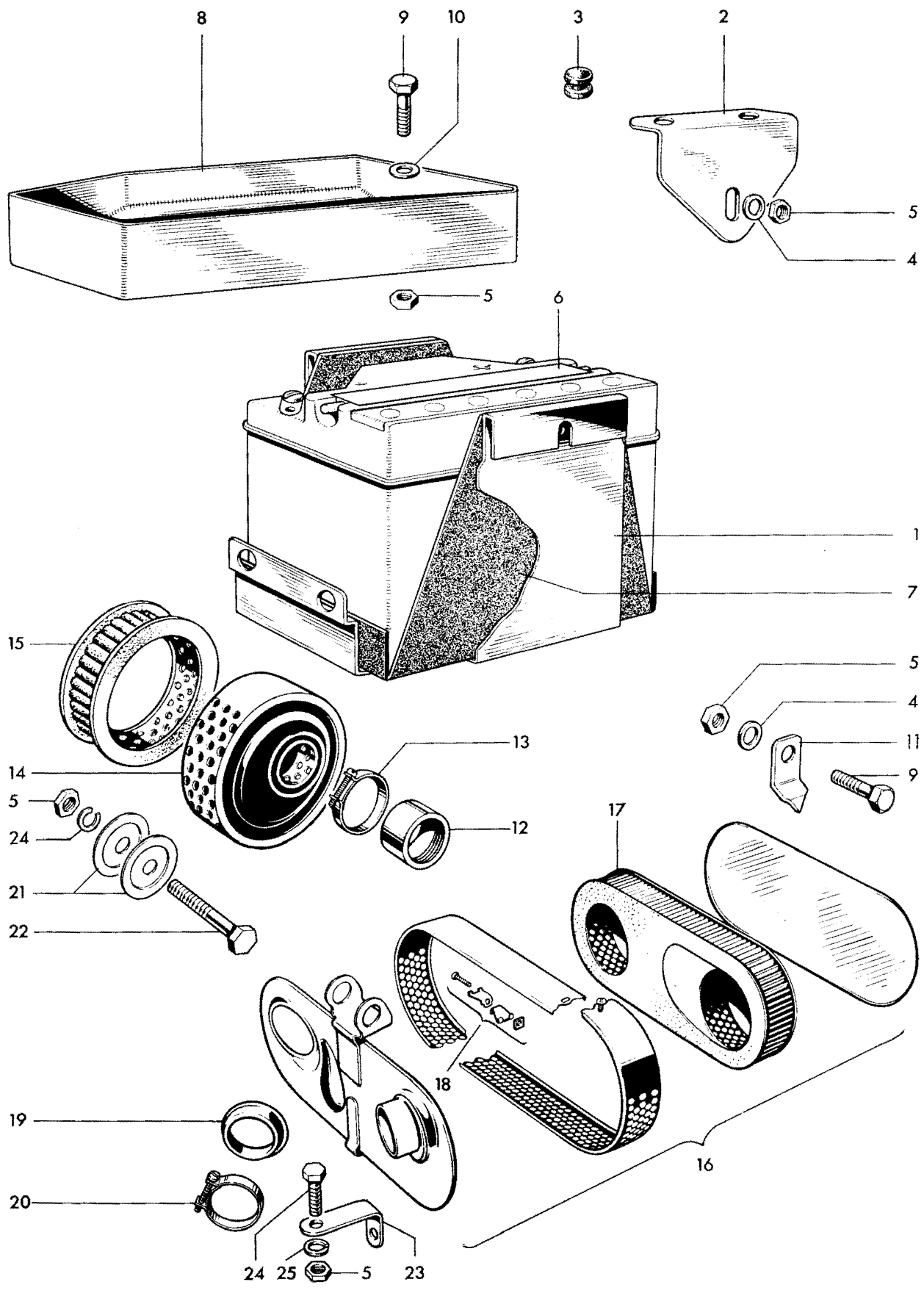

Fig. 27. BATTERY CARRIER AND AIR FILTERS

BATTERY CARRIER AND AIR FILTERS

1	*F6891	Battery carrier	1						
2	*F6897	Retainer	2						
3	*E6226	Rubber	4						
4	S25-1	Plain washer	3						
5	F879	Nut	7						
6	*PUZ5A	Battery	1						
7	*F6969	Battery carrier lining	1						
8	F6901	Tool tray	1						
9	F1369	Bolt ($\frac{5}{8}$ in. U.H.)	3						
10	S25-13	Plainwasher	2						
11	F6883	Inflator bracket	2						
12	E4576	Adaptor sleeve	1	6T					
13	F5625	Clip	1	6T					
14	F6430	AIR FILTER	1	6T					
15	F4811	Filter element (felt)	1	6T					
14	F6433	AIR FILTER	1	U.S.A. 6T					
15	F5694	Filter element (paper)	1	U.S.A. 6T					
12	F5958	Adaptor sleeve	1	} TR6 & Eastern					
13	F6074	Clip	1		} T120				
14	F6431	AIR FILTER	1	} U.S.A. TR6					
15	F5764	Filter element (coarse felt)	1		} U.S.A. TR6				
14	F6432	AIR FILTER	1	} Western T120					
15	F5694	Filter element (paper)	1		} Western T120				
16	E5262	AIR FILTER	1			} Western T120			
17	E5267	Filter element	1				} Western T120		
18	F4810	Clip	1					} Western T120	
19	E5268	Rubber connector	2						} Western T120
20	F6036	Clip	2						
21	F5857	Cap	2	} Western T120					
22	F4743	Bolt ($2\frac{1}{8}$ in. U.H.)	1		} Western T120				
23	F6061	Bracket	1			} Western T120			
24	DS57	Bolt ($\frac{7}{16}$ in. U.H.)	1				} Western T120		
25	S26-2	Spring washer	2					} Western T120	

*Some early models have two 6 volt batteries. These are interchangeable as a group but the following part numbers apply to this condition (Not Illustrated)

PUZ5A	Battery	use MKZ9E (2 off)
F6891	Battery carrier	use F7083
F6894	Rear strap	use F7086
F6897	Retainer	use F7085 (1 off)
E6226	Rubber	use F7045 (3 off)
—	Rubber (between batteries)	use F7046 (2 off)
F6969	Battery carrier lining	use F7087

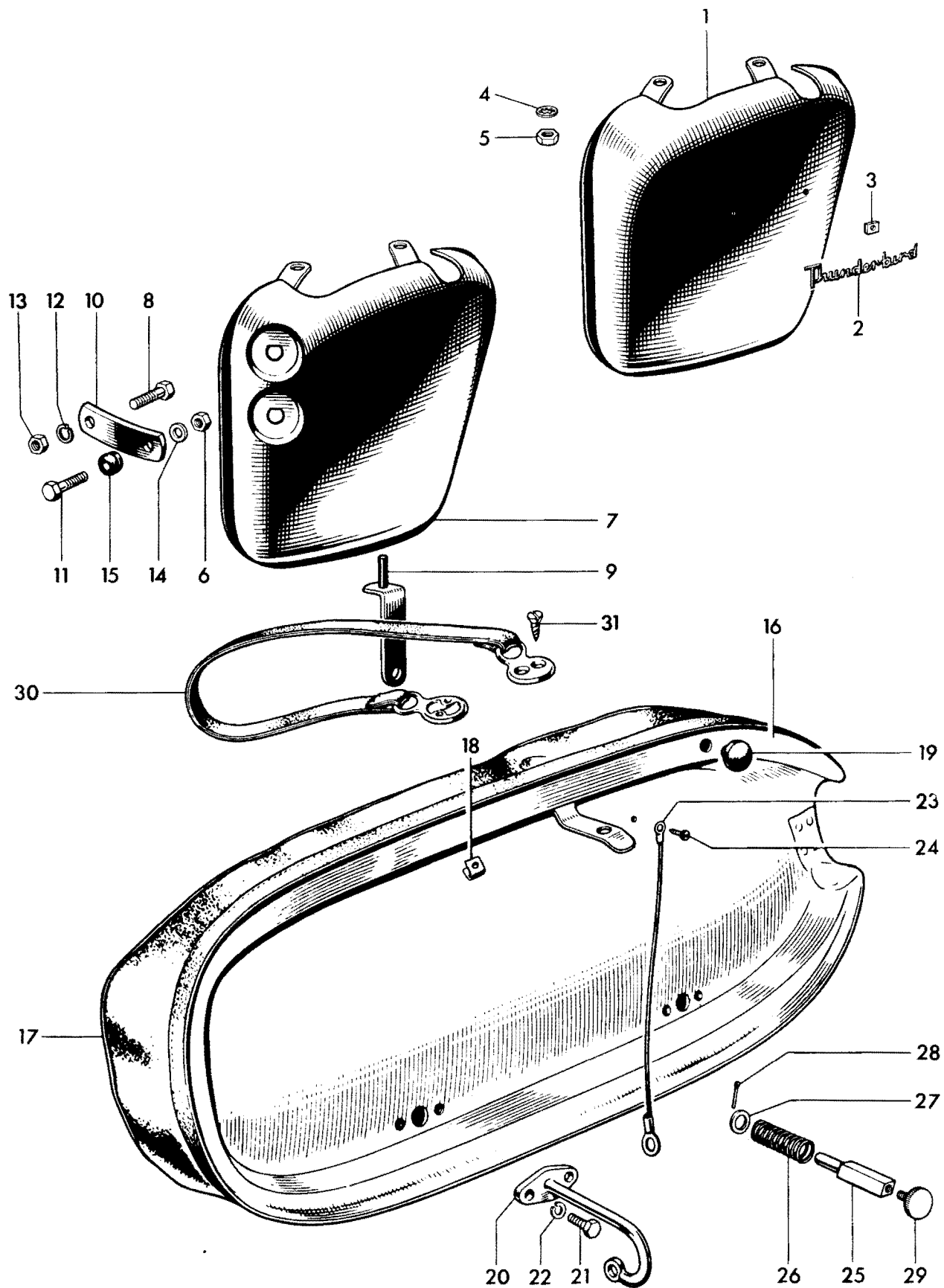

Fig. 28. PANEL AND TWINSEAT

PANEL AND TWINSEAT

1	F6930	Left panel	1	6T
2	F6946	Motif "Thunderbird"	1	6T
3	F4317	Spire nut	2	6T
4	E1612	Serrated washer	2	
5	13104/00/2	Nut	2	
6	15104/00/2	Self-locking nut	1	
7	F6931	Switch panel	1	TR6 & T120
7	F6962	Left panel	1	TR6C & T120TT
8	F1369	Bolt ($\frac{5}{8}$ in. U.H.)	1	
9	F5939	Fixing bracket	1	
10	F5923	Link	1	
11	11104/06/2	Bolt ($\frac{3}{4}$ in. U.H.)	1	
12	S26-2	Spring washer	1	
13	F879	Nut	1	
14	S25-43	Washer	1	
15	F5466	Grommet	3	
16	F5239	TWINSEAT	1	
17	F5418	Twinsat cover c/w clips	1	
18	F4475	Clip	as required	
19	F4898	Rubber buffer	2	
20	F4222	Hinge	2	
21	DS57	Bolt ($\frac{7}{8}$ in. U.H.)	4	
22	S26-2	Spring washer	4	
23	D374	Check wire	1	
24	F4483	Self tapping screw	1	
25	F4226	Seat catch plunger	1	
26	F4228	Spring	1	
27	E1719A	Plain washer	1	
28	$\frac{3}{32}$ in. x $\frac{1}{2}$ in.	Split pin... ..	1	
29	F6659	Knob	1	
30	F4361	Safety strap	as required	
31	F4365	Self tapping screw	4	

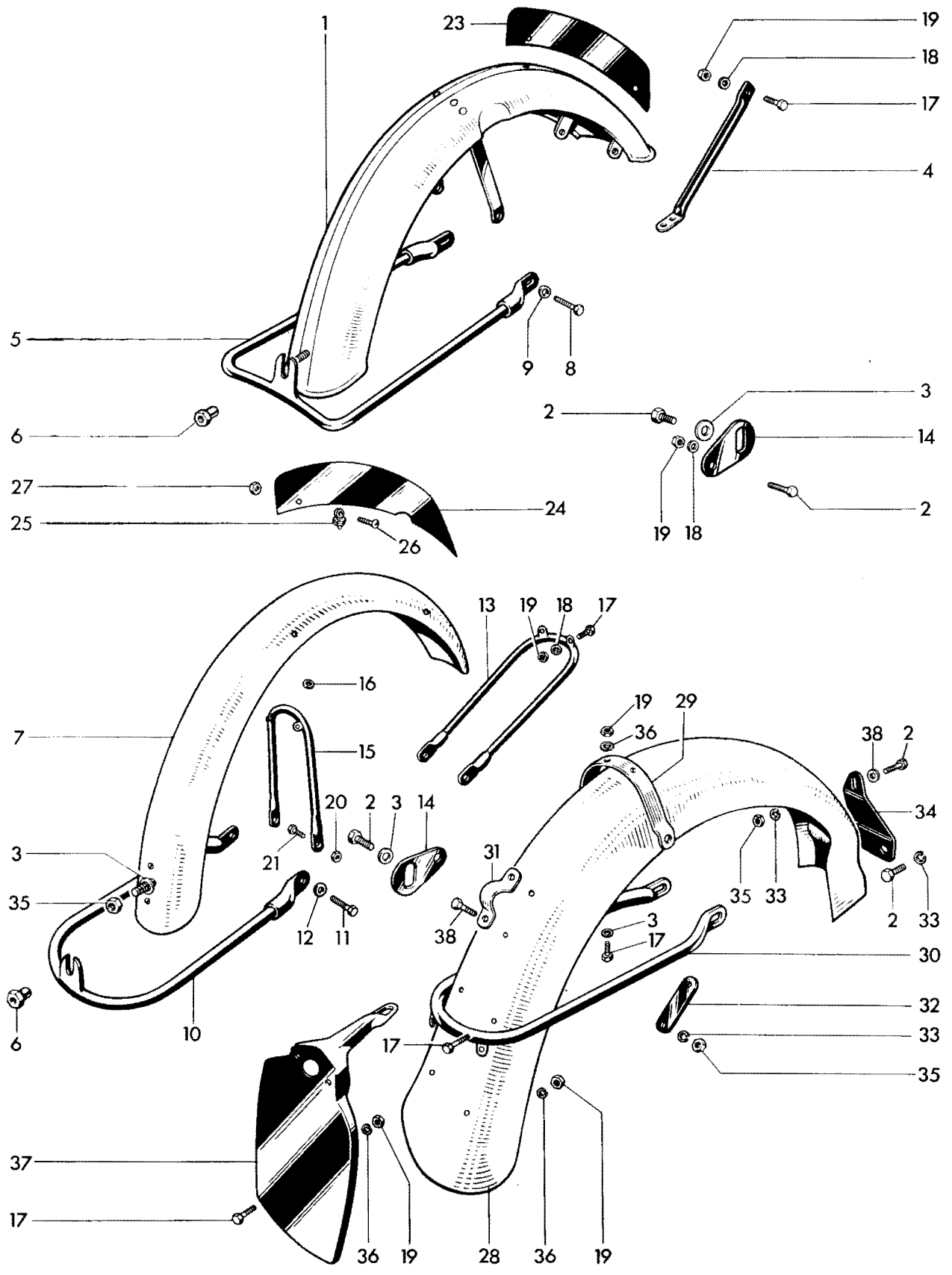

Fig. 29. MUDGUARDS (STANDARD)

MUDGUARDS (STANDARD)

1	H1901	Front mudguard	1	6T
2	F929	Bolt ($\frac{1}{2}$ in. U.H.)	5	
3	F4299	Plain washer	4	
4	H1964	Front stay	2	
5	H1100	Bottom stay	1	6T
6	NS362	Spigot nut	1	
7	H1675	Mudguard blade	1	TR6, T120
8	W62	Bolt	2	6T
9	S25-2	Plain washer	2	6T
10	H1482	Bottom stay	1	TR6, T120
11	H424	Bolt ($\frac{3}{8}$ in. U.H.)	2	TR6, T120
12	S25-71	Plain washer	2	TR6, T120
13	H1681	Front stay	1	TR6, T120
14	H1685	Bracket	2	
15	H1683	Mudguard bridge	1	TR6, T120
16	WE170	Fibre washer	2	
17	DS57	Bolt ($\frac{7}{8}$ in. U.H.)	10	
18	S25-1	Plain washer	6	
19	F879	Nut	17	
20	T224	Nut	2	TR6, T120
21	DS55	Bolt ($\frac{15}{16}$ in. U.H.)	2	TR6, T120
22	F1369	Bolt ($\frac{5}{8}$ in. U.H.)	2	6T
23	F6469	Number plate	1	6T
24	F6470	Number plate	1	TR6, T120
25	H741	Clip assembly	2	
26	H687	Screw ($\frac{3}{8}$ in. U.H.)	2	
27	H745	Nut	2	
28	F5984	Mudguard blade	1	
29	F6915	Mudguard bridge	1	
30	F5424	Lifting handle	1	
31	F5994	Clip	1	
32	F6031	Backing plate	1	
33	S26-3	Spring washer	9	
34	F6851	Bracket	1	
35	S1-51	Nut	3	
36	S26-2	Spring washer	10	
37	F5924	Number plate	1	
38	H590	Bolt ($\frac{9}{16}$ in. U.H.)	2	

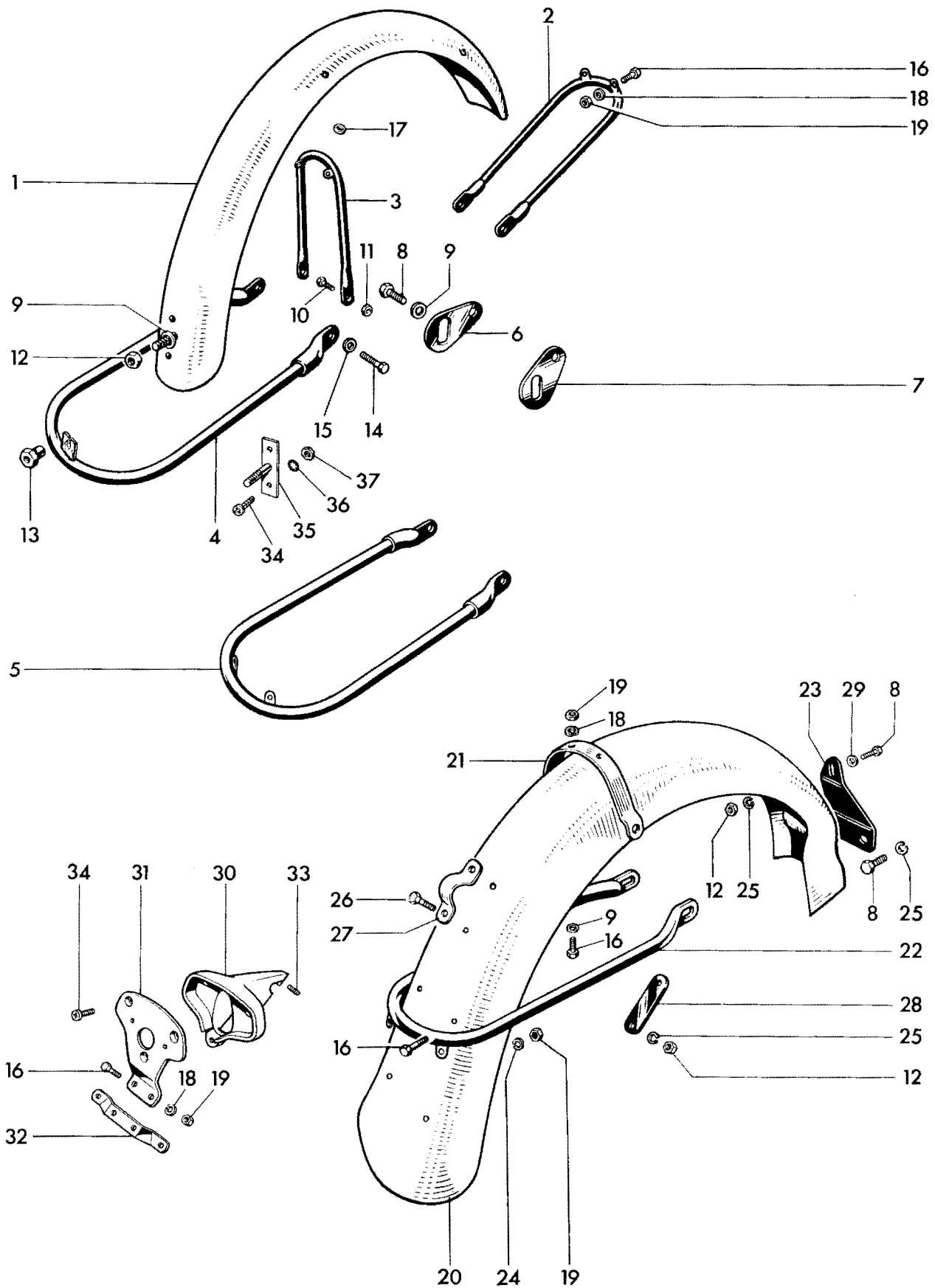

Fig. 30. FENDERS (U.S.A.)

Ref. No.	Part No.	DESCRIPTION	QUANTITY	REMARKS
FENDERS (U.S.A.)				
1	H1677	Front fender	1	6T, Eastern TR6C, TR6R
1	H1687	Front fender (aluminium)	1	Western TR6C, T120TT
1	H1997	Front fender (stainless steel)	1	T120R
2	H1681	Front stay	1	
3	H1683	Centre bridge	1	
4	H1678	Bottom stay	1	} 6T, Eastern TR6C, TR6R, T120R
5	H1273	Bottom stay	1	
6	H1685	Bracket	2	} 6T, Eastern TR6C, TR6R, T120R
7	H1688	Bracket	2	
8	F929	Bolt ($\frac{1}{2}$ in. U.H.)	5	
9	F4299	Plain washer	5	
10	DS55	Bolt ($\frac{5}{16}$ in. U.H.)	2	
11	T224	Nut	2	
12	S1-51	Nut	4	
13	NS362	Spigot nut	1	
14	W62	Bolt ($\frac{1}{8}$ in. U.H.)	2	
15	S26-3	Spring washer	2	
16	DS57	Bolt ($\frac{7}{8}$ in. U.H.)	10	
17	WE170	Fibre washer	4	
18	S25-1	Plain washer	13	
19	F879	Nut	13	
20	F6965	Rear fender	1	6T, Eastern TR6C, TR6R
20	F5955	Rear fender (aluminium)	1	Western TR6C, T120TT
20	F6967	Rear fender (stainless steel)	1	T120R
21	F6915	Fender bridge	1	
22	F5424	Lifting handle	1	
23	F6851	Bracket	1	
24	S26-2	Spring washer	2	
25	S26-3	Spring washer	5	
26	H590	Bolt ($\frac{9}{16}$ in. U.H.)	2	
27	F5994	Clip	1	
28	F6031	Backing plate	1	
29	F6310	Plain washer	1	
30	F6847	Tail lamp adapter	1	
31	F6849	Tail lamp plate	1	
32	F6850	Number plate bracket	1	
33	E2980	Stud ($\frac{15}{8}$ in. O.A.)	1	
34	F4715	Screw ($\frac{13}{32}$ in. U.H.)	5	
35	H1998	Backing strip	1	
36	GS299	Serrated washer	2	
37	F3799	Nut	2	

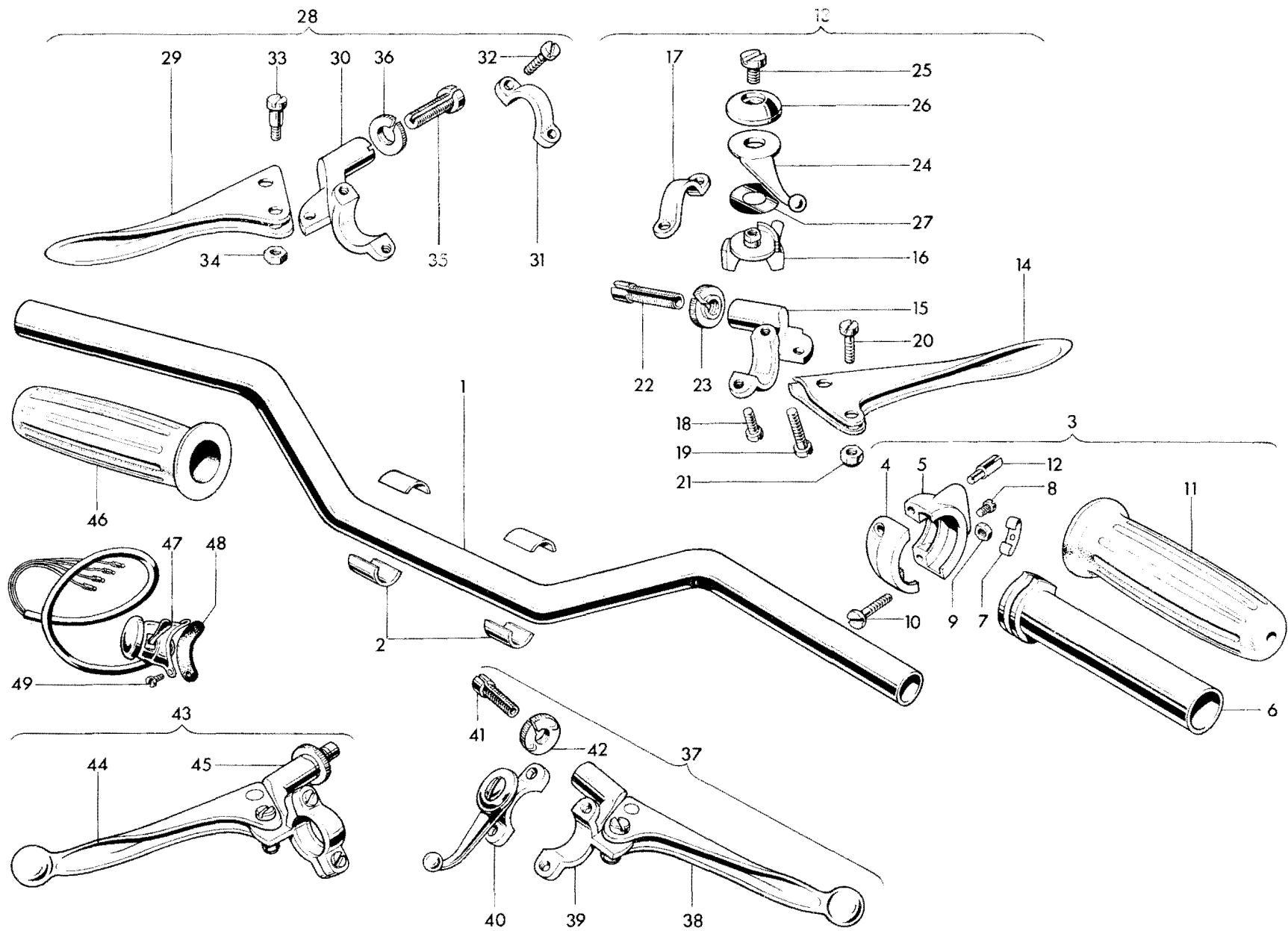

Fig. 31. HANDLEBARS AND CONTROL LEVERS

Ref. No.	Part No.	DESCRIPTION	QUANTITY	REMARKS
HANDLEBARS AND CONTROL LEVERS (SEE ALSO PAGE 82)				
1	H.1871	Handlebar	1	6T, TR6, T120
2	H.1425	Packing piece	4	
3	16/362	TWISTGRIP	1	6T, TR6, T120
4	16/328	Body top half	1	
5	16/329	Body bottom half	1	
6	16/091	Rotor	1	
7	16/008	Friction spring	1	
8	16/009	Friction spring screw	1	
9	16/010	Locknut	1	
10	11/013	Screw	2	
11	366/012	Grip	1	
12	16/011	Cable stop	1	
13	18/1004	FRONT BRAKE AND AIR LEVER ASSEMBLY	1	6T
13	18/999	FRONT BRAKE LEVER ASSEMBLY	1	T120
14	18/535	Brake lever	1	
15	18/1014	Lever bracket	1	6T
15	18/1013	Lever bracket	1	T120
16	12/619	Control body	1	6T
17	12/595	Clamp	1	T120
18	11/014	Screw	1	
19	11/013	Screw	1	
20	18/087	Fulcrum screw	1	
21	18/053	Self locking nut	1	
22	18/1005	Cable adjuster	1	
23	18/1006	Thumb nut	1	
24	12/556	Lever	1	
25	12/607	Bolt	1	
26	12/606	Cap	1	
27	12/033	Spring washer	1	
28	18/1000	CLUTCH LEVER ASSEMBLY	1	6T, T120
29	18/528	Clutch lever	1	
30	18/1009	Clutch lever bracket	1	
31	12/595	Clamp	1	
32	11/014	Screw	2	
33	18/087	Fulcrum screw	1	
34	18/053	Self locking nut	1	
35	18/1005	Cable adjuster	1	
36	18/1006	Thumb nut	1	
37	18/978	FRONT BRAKE AND AIR LEVER ASSEMBLY	1	TR6
37	18/951	FRONT BRAKE LEVER ASSEMBLY	1	T120R, T120TT
38	18/754	Brake lever (ball end)	1	
39	18/776	Lever bracket	1	TR6
39	18/777	Lever bracket	1	T120R, T120TT
40	12/594	Control body	1	
41	18/838	Cable adjuster	2	
42	18/839	Thumb nut	2	
43	18/952	CLUTCH LEVER ASSEMBLY	1	TR6, T120TT
44	18/752	Clutch lever (ball end)	1	
45	18/773	Lever bracket	1	
46	366/011	Handlebar grip	1	
47	31563	Horn push and dip switch	1	
48	380459	Backing rubber	1	
49	H1994	Self-tapping screw ($\frac{1}{2}$ in. U.H.)	2	

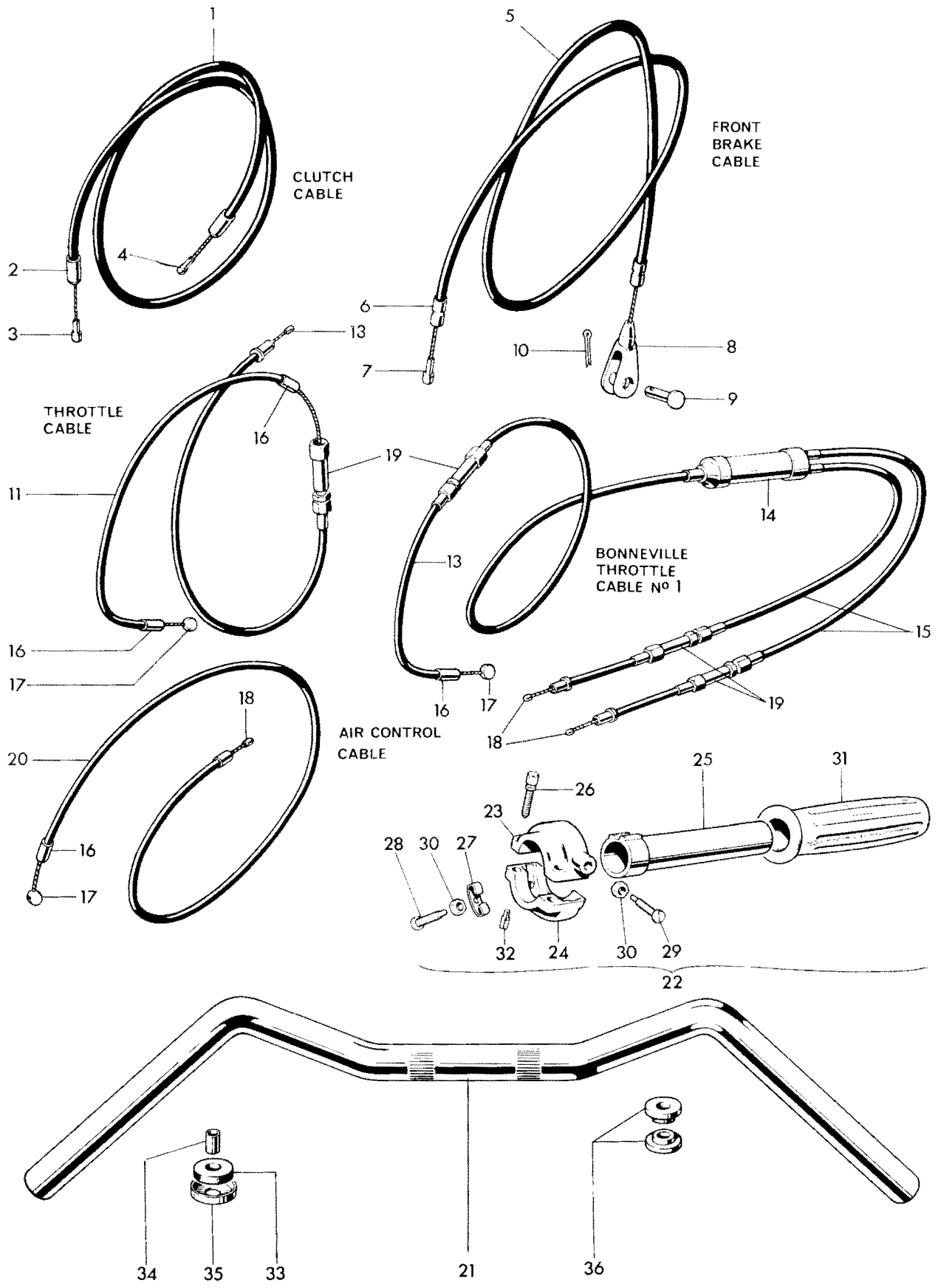

Fig. 32. CONTROL CABLES AND AMERICAN HANDLEBARS

CONTROL CABLES AND AMERICAN HANDLEBARS

1	D565	CLUTCH CABLE	1	
2	D103	Ferrule	2	
3	D506	Nipple (Handlebar end)	1	
4	DS73	Nipple	1	
5	D558	FRONT BRAKE CABLE	1	
5	D559	FRONT BRAKE CABLE	1	All U.S.A. models
6	D103	Ferrule	2	
7	D506	Nipple (Handlebar end)	1	
8	W593	Fork end	1	
9	WF32	Pivot pin... ..	1	
10	$\frac{1}{16}$ in. x $\frac{5}{8}$ in.	Split pin	1	
11	D495	THROTTLE CABLE	1	6T
11	D519	THROTTLE CABLE	1	TR6
11	D528	Throttle cable	2	T120R, T120TT
12	D499	THROTTLE CABLE	1	T120
13	D500	Twistgrip cable	1	T120
14	244/104	Junction block	1	
15	D423	Carburetter cable	2	T120
16	D101	Ferrule	3	
17	D83	Nipple	5	
18	NS191	Nipple	1	
19	D104	Adjuster	3	
20	D435	Air control cable	1	6T
20	D507	Air control cable	1	TR6
21	H1869	American handlebar	1	U.S.A. 6T
21	H1870	American handlebar	1	TR6R, T120R
21	H1511	American handlebar	1	TR6C, T120TT
22	313/8	TWIN ROTOR TWISTGRIP	1	T120R, T120TT
23	313/008	Body top half	1	
24	313/009	Body bottom half	1	
25	313/013	Rotor	1	
26	4/048	Bolt	2	
27	16/008	Friction spring	1	
28	210/007	Adjuster screw	1	
29	210/008	Rotor stop	1	
30	210/009	Nut	2	
31	366/012	Grip	1	
32	16/011	Cable stop	2	
33	H1580	Steady rubber	2	
34	H1581	Distance piece	2	
35	F3814	Cup	2	
36	H1616	Solid bush (for handlebar-mounted windscreen)	4	

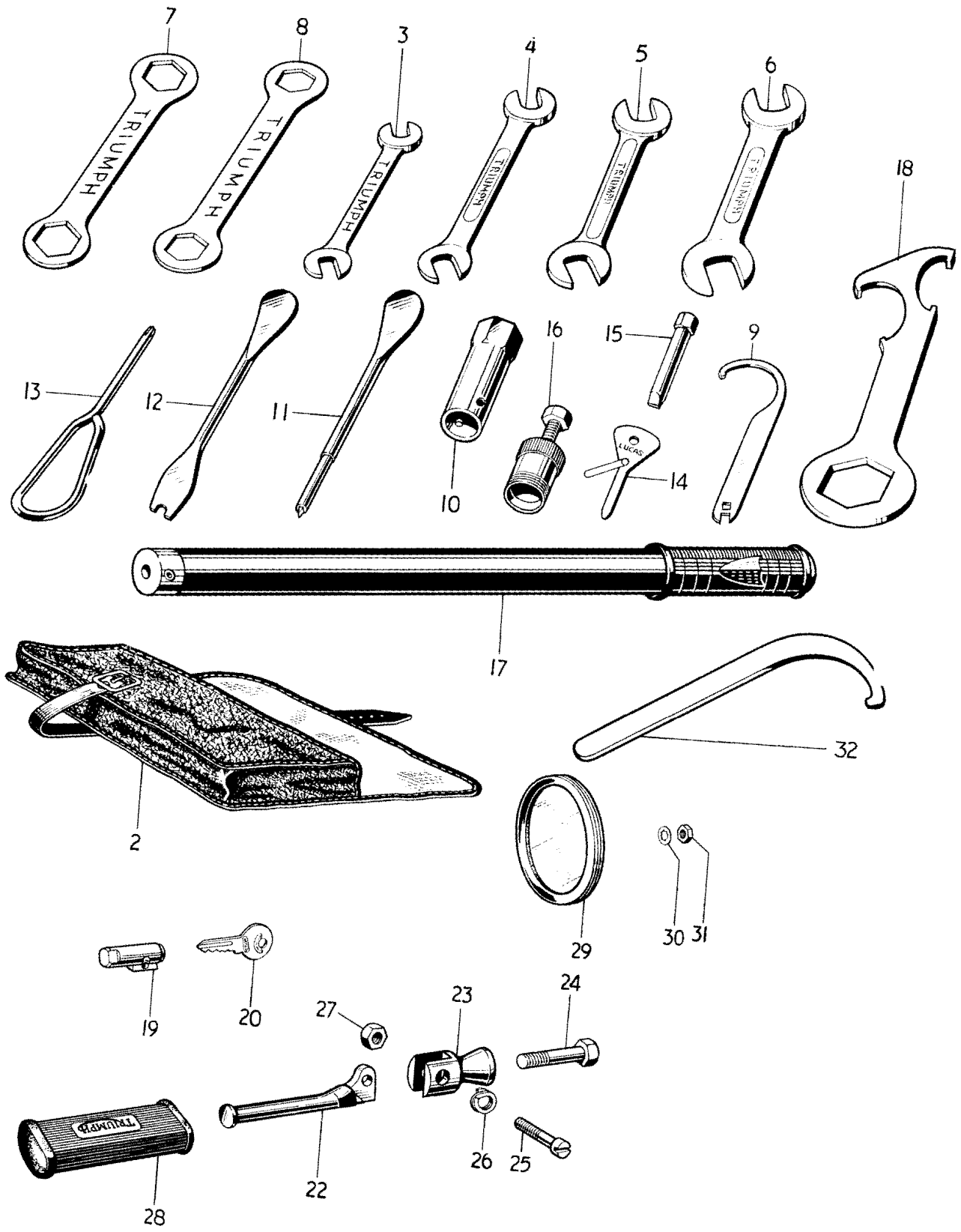

Fig. 33. TOOLKIT, FRAME LOCK, PILLION FOOTRESTS AND LICENCE HOLDER

TOOLKIT, FRAME LOCK, PILLION FOOTRESTS AND LICENCE HOLDER

1	D365	TOOLKIT COMPLETE	1	
2	WA58	Tool roll	1	
3	D360	Open spanner, $\frac{1}{8} \times \frac{5}{32}$ in. Whit.	1	
4	D361	Open spanner, $\frac{3}{16} \times \frac{1}{4}$ in. Whit.	1	
5	NA55	Open spanner, $\frac{1}{2} \times \frac{5}{16}$ in. Whit.	1	
6	DA16	Open spanner, $\frac{3}{8} \times \frac{7}{16}$ in. Whit.	1	
7	PA57	Ring spanner, $\frac{1}{2} \times \frac{9}{16}$ in. Whit.	1	
8	D311	Ring spanner, $\frac{5}{8} \times \frac{11}{16}$ in. Whit.	1	
9	D362	"C" spanner and tappet key	1	
10	D87	Plug spanner	1	
11	D363	Tyre lever and screwdriver	1	
12	D364	Tyre lever and clutch key	1	
13	D336	Phillips No. 3 screwdriver	1	
14	400935	Screwdriver	1	
15	D496	Screwdriver for chain tensioner	1	
16	DA50/1	Clutch hub extractor	as required	
17	D296	Tyre inflator	1	
18	D220	Fork spanner (for cap nut)	as required	
19	D402/3	FRAME LOCK c/w KEYS	1	
20	D403	Key (state number)	1	
21	F5552	PILLION FOOTREST	2	
22	F1694	Pedal	2	
23	F2268	Hanger	2	
24	F5535	Bolt ($\frac{13}{16}$ in. U.H.)	2	
25	F2271	Pivot bolt	2	
26	F2277	Thackeray (spring) washer	2	
27	S1-51	Nut	2	
28	F1695	Pedal rubber	2	
29	D261	Licence holder	1	
30	E1612	Serrated washer	1	
31	F879	Nut	1	
32	D527	Fork spanner (for sleeve nut)	as required	

CARBURETTER COMPLETE
REF. N21

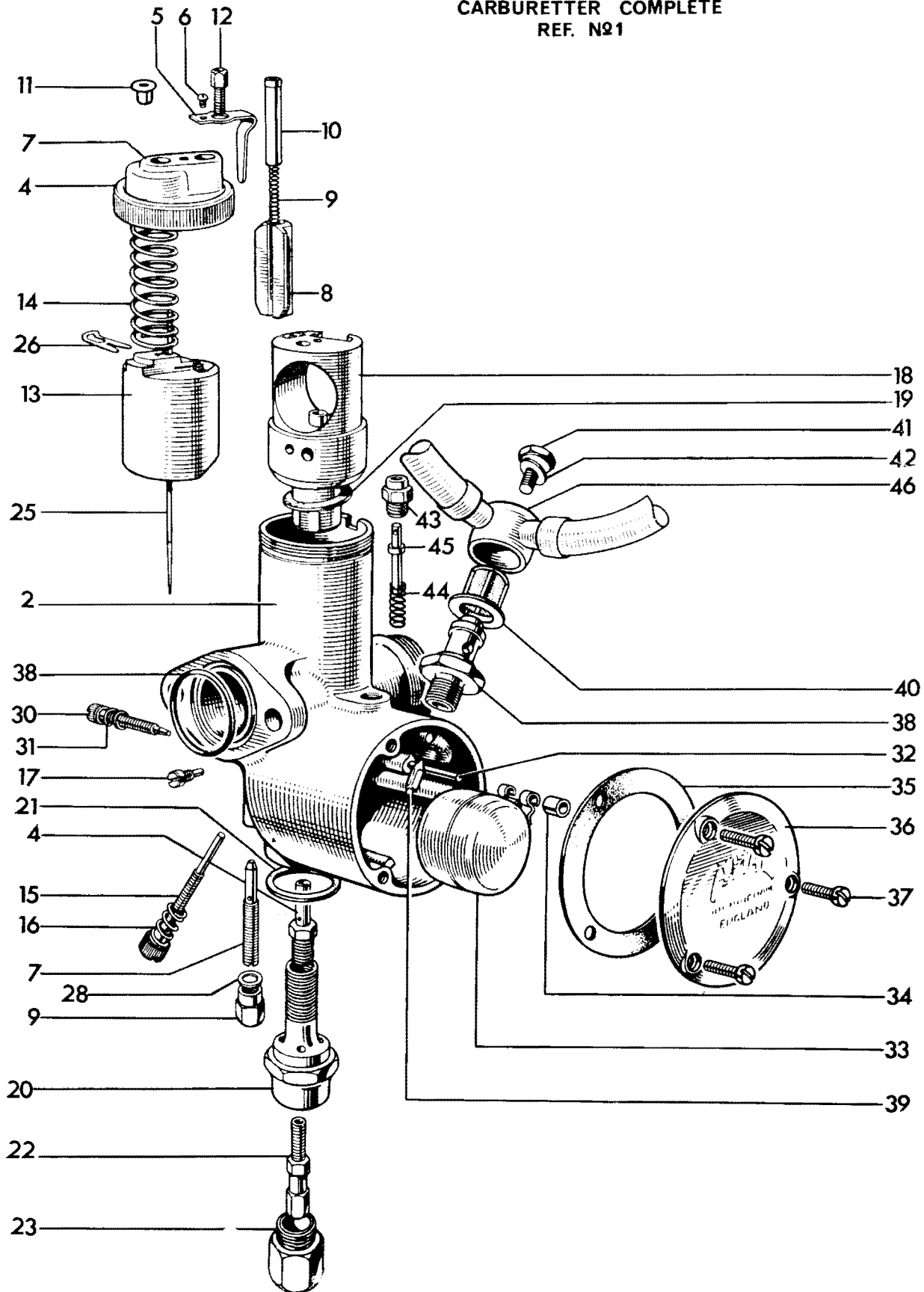

Fig. 34. AMAL CARBURETTER, 6T

AMAL CARBURETTER 6T

1	376/303	CARBURETTER	1	
2	376/003	Mixing chamber, 1 $\frac{1}{16}$ in. choke	1	
3	244/1048	"O" ring seal	1	
4	376/065	Mixing chamber cap	1	
5	29/307	Spring	1	
6	4/241	Screw	1	
7	376/107	Mixing chamber top	1	
8	376/062	Air valve	1	
9	4/046	Spring	1	
10	6/047	Air valve guide	1	
11	6/132A	Throttle cable ferrule	1	
12	4/035	Air cable adaptor	1	
13	376/060	Throttle valve (state cutaway)	1	/4 std.
14	376/061	Throttle return spring	1	
15	376/068	Throttle stop screw	1	
16	376/069	Stop screw spring	1	
17	376/070	Peg screw	1	
18	376/057	Jet block (1 $\frac{1}{16}$ in. choke)	1	
19	376/067	Joint washer	1	
20	376/073	Jet holder	1	
21	376/074	Fibre washer	1	
22	376/100	Main jet (state size)	1	{ 230 std., 270 U.S.A.
23	376/075	Cover nut	1	
24	376/072	Needle jet (0.106)	1	
25	376/063	Needle (Type C)	1	
26	4/230	Needle clip	1	
27	376/076	Pilot jet (state size)	1	25 std.
28	116/017	Fibre washer	1	
29	376/095	Cover nut	1	
30	332/017	Air adjusting screw	1	
31	4/148	Spring	1	
32	376/085	Float spindle	1	
33	376/083	Float	1	
34	376/094	Bush	1	
35	376/078	Joint washer	1	
36	376/077	Cover	1	
37	376/079	Screw	3	
38	376/088	Needle seating	1	
39	376/089	Needle	1	
40	376/093	Filter	1	
41	376/091	Bolt	1	
42	376/092	Fibre washer	1	
43	376/086	Tickler	1	
44	376/087	Tickler spring	1	
45	343/011	Tickler body	1	
46	F5339	Petrol pipe	1	

CARBURETTER COMPLETE
REFERENCE N°1

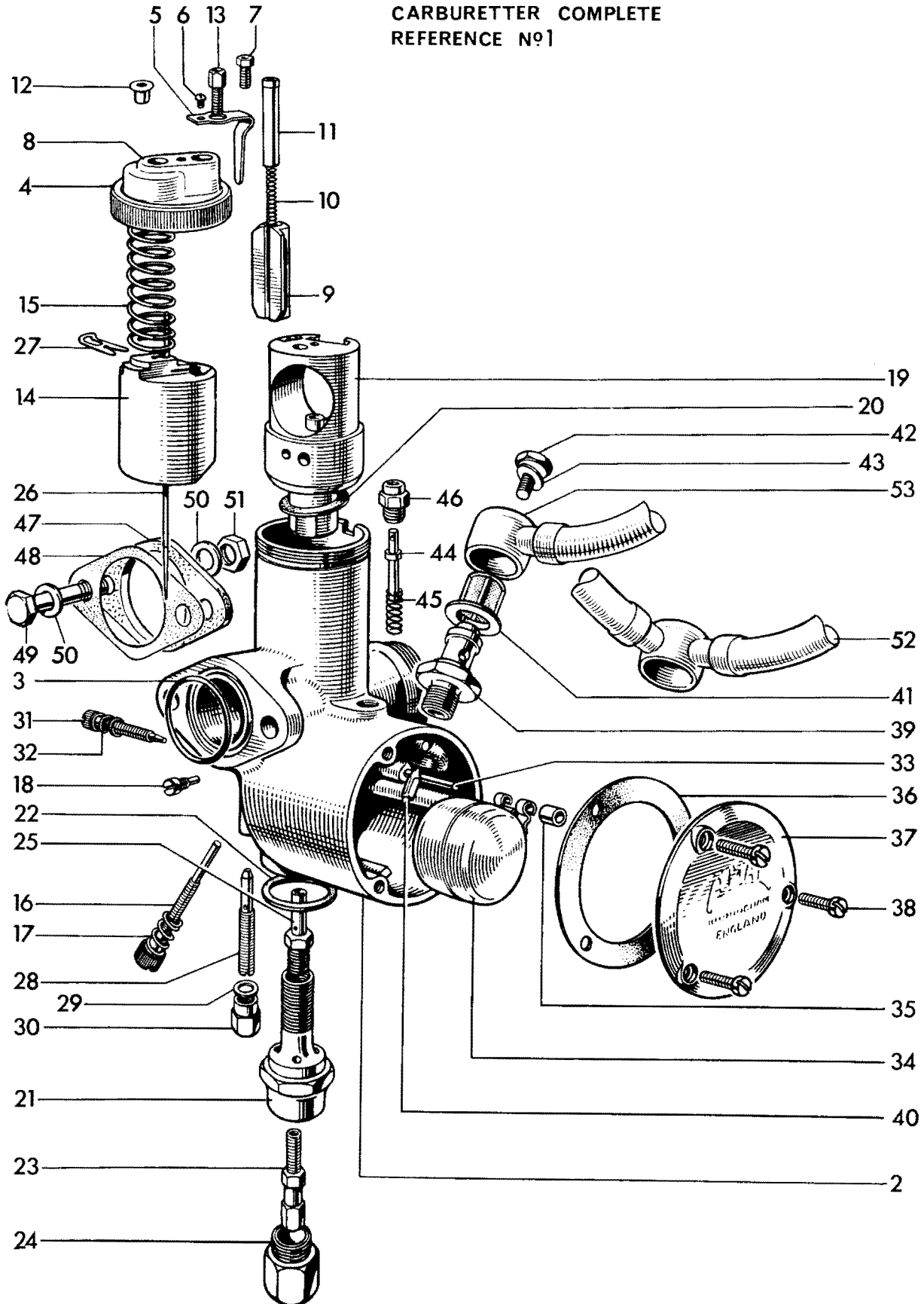

Fig. 35. AMAL CARBURETTER, TR6 AND T120

Ref. No.	Part No.	DESCRIPTION	QUANTITY	REMARKS
		AMAL CARBURETTER, TR6 & T120		
			TR6	T120 & T120R
1	389/97	CARBURETTER	1	-
1	389/203	CARBURETTER	-	2
2	389/002	Mixing chamber (1 $\frac{1}{8}$ in. choke)	1	2
3	244/1048	"O" ring seal	1	2
4	389/065	Mixing chamber cap	1	2
5	29/307	Spring	1	2
6	4/241	Screw	1	2
7	4/137A	Plug screw	-	2
8	389/107	Mixing chamber top	1	2
9	389/062	Air valve	1	-
10	4/046	Spring	1	-
11	29/057	Air valve guide	1	-
12	6/132A	Throttle cable ferrule	1	2
13	4/035	Air cable adjuster	1	-
14	389/060	Throttle valve (state cutaway)	1	2 See Pages 7 to 15
15	389/061	Throttle return spring	1	2
16	376/068	Throttle stop screw	1	2
17	376/069	Stop screw spring	1	2
18	376/070	Peg screw	1	2
19	389/109	Jet block (1 $\frac{1}{8}$ in. choke)	1	2 For T120 use 389/056
20	376/067	Joint washer	1	2
21	376/073	Jet holder	1	2
22	376/074	Fibre washer	1	2
23	376/100	Main jet (state size)	1	2 See Pages 7 to 15
24	376/075	Cover nut	1	2
25	376/072	Needle jet (0.106)	1	2
26	389/063	Needle (Type D)	1	2
27	4/230	Needle clip	1	2
28	376/076	Pilot jet (state size)	1	2 See Pages 7 to 15
29	116/162	Fibre washer	1	2
30	376/095	Cover nut	1	2
31	332/017	Air adjusting screw	1	2
32	4/148	Spring	1	2
33	376/085	Float spindle	1	2
34	376/083	Float	1	2
35	376/094	Bush	1	2
36	376/078	Joint washer	1	2
37	376/077	Cover	1	2
38	376/079	Screw	3	6
38	376/151	Screw	1	6
39	376/088	Needle seating	1	2
40	376/089	Needle	1	2
41	376/093	Filter	1	2
42	376/091	Bolt	1	2
43	376/092	Fibre washer	1	2
44	376/086	Tickler	1	2
45	376/087	Tickler spring	1	2
46	343/011	Tickler body	1	2
47	E2968	Insulating block	-	2
48	NA43A	Joint washer	-	2
49	F2603	Bolt ($\frac{1}{8}$ in. U.H.)	-	2
50	S25-3	Plain washer	-	4
51	T224	Nut	-	4
52	F5339	Petrol pipe	1	-
53	F5462	Petrol pipe	-	1

CARBURETTER COMPLETE
REFERENCE N°1

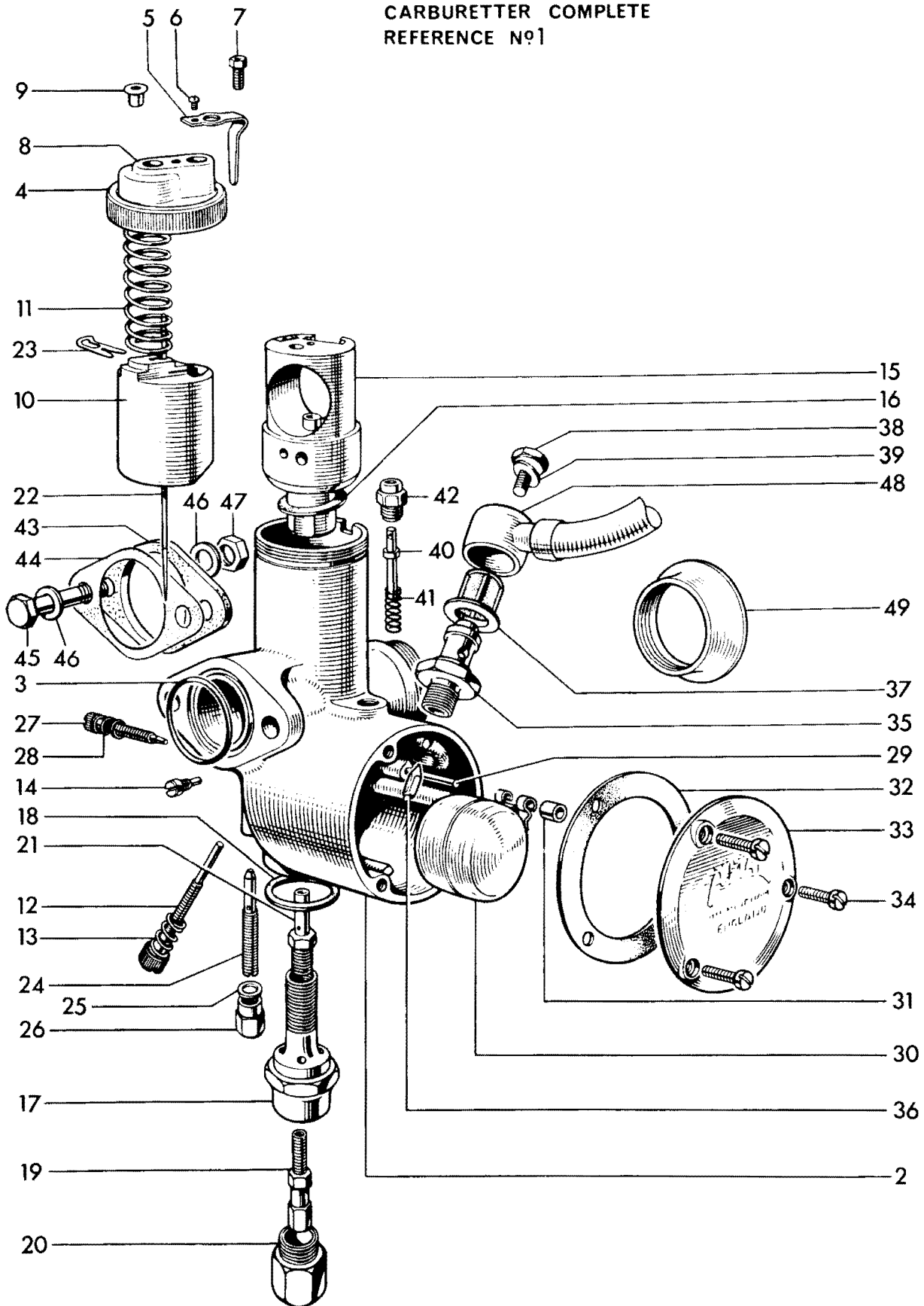

Fig. 36. AMAL CARBURETTER, T120TT

Ref. No.	Part No.	DESCRIPTION	QUANTITY	REMARKS
AMAL CARBURETTER, T120TT				
1	389/95	CARBURETTER	2	
2	389/030	Mixing chamber (1 $\frac{3}{16}$ in. choke)	2	
3	244/1048	'O' ring seal	2	
4	389/065	Mixing chamber cap	2	
5	29/307	Spring	2	
6	4/241	Screw	2	
7	4/137A	Plug screw	2	
8	389/107	Mixing chamber top	2	
9	6/132A	Throttle cable ferrule	2	
10	389/060	Throttle valve (4 cutaway)	2	
11	376/132	Throttle return spring	2	
12	376/068	Throttle stop screw	2	
13	376/069	Stop screw spring	2	
14	376/070	Peg screw	2	
15	389/058	Jet block (1 $\frac{3}{16}$ in. choke)	2	
16	376/067	Joint washer	2	
17	376/073	Jet holder	2	
18	376/074	Fibre washer	2	
19	376/100	Main jet (330)	2	
20	376/075	Cover nut	2	
21	376/072	Needle jet (0.106)	2	
22	389/063	Needle (Type D)	2	
23	4/230	Needle clip	2	
24	376/076	Pilot jet (25)	2	
25	116/162	Fibre washer	2	
26	376/095	Cover nut	2	
27	332/017	Air adjusting screw	2	
28	4/148	Spring	2	
29	376/085	Float spindle	2	
30	376/083	Float	2	
31	376/094	Bush	2	
32	376/078	Joint washer	2	
33	376/077	Cover	2	
34	376/151	Screw	6	
35	376/088	Needle seating	2	
36	376/089	Needle	2	
37	376/093	Filter	2	
38	376/091	Bolt	2	
39	376/092	Fibre washer	2	
40	376/086	Tickler	2	
41	376/087	Tickler spring	2	
42	343/011	Tickler body	2	
43	E4918	Insulating block	2	
44	E4919	Joint washer	2	
45	F2603	Bolt (1 $\frac{5}{16}$ in. U.H.)	2	
46	S25-3	Plain washer	3	
47	T224	Nut	4	
48	F5462	Petrol pipe	1	
49	389/066	Air intake tube	2	

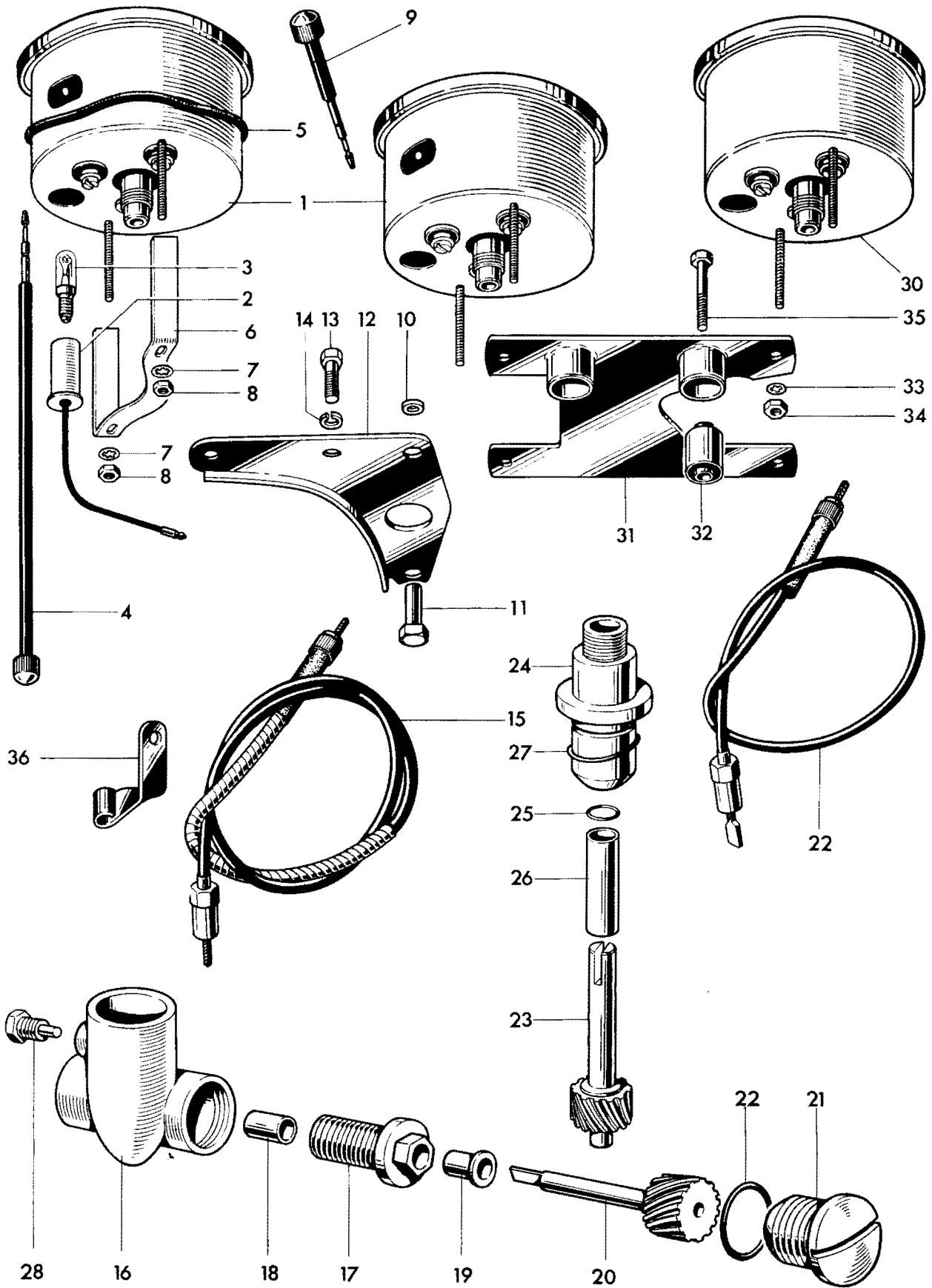

Fig. 37. SPEEDOMETER AND TACHOMETER

SPEEDOMETER AND TACHOMETER

1	SSM5002/00	Speedometer head MPH	1	6T
1	SSM5002/01	Speedometer head KPH		Alternative 6T
1	SSM5001/00	Speedometer head MPH	1	TR6, T120
1	SSM5001/01	Speedometer head KPH		Alternative TR6, T120
2	554734	Bulb holder	1	
3	987	Bulb, 3.W. M.E.S.	1	
4	41-118-127-72	Trip control	1	} 6T
5	31-753-778	Rubber ring	1	
6	31-674-188-01	Fixing strap	1	
7	30-283-014-11	Washer	2	
8	30-277-023-11	Nut	2	
9	41-148-203-10	Trip control	1	
10	H1702	Distance piece	2	} TR6, T120
11	H1701	Sleeve nut	2	
12	H1668	Bracket	1	
13	DS57	Bolt ($\frac{7}{16}$ in. U.H.)	2	
14	S26-2	Spring washer	2	
15	D609	Speedometer cable (65 ins. long)	1	
16	E5756	TACHOMETER GEARBOX	1	} TR6R, T120R, T120TT
17	E5153	Securing screw	1	
18	E5156	Bush	1	
19	E5155	Flanged bush	1	
20	E5157	Driving gear	1	
21	E5759	End cap	1	
22	E6300	"O" ring	1	
23	E5578	Driven gear	1	
24	E6122	Driven gear housing	1	
25	E6299	"O" ring	1	
26	E6124	Bush	1	
27	E3309	"O" ring	1	
28	E5881	Set screw	1	
29	D578	Tachometer cable (28 in. long)	1	
30	RSM3003/01	Tachometer	1	
31	H1946	MOUNTING BRACKET	1	
32	H1929	Metalastik bush	2	
33	30-282-014-11	Washer	2	
34	30-276-037-11	Nut	2	
35	H1086	Bolt ($1\frac{3}{8}$ in. U.H.)	2	
36	H1698	Cable bracket	1	

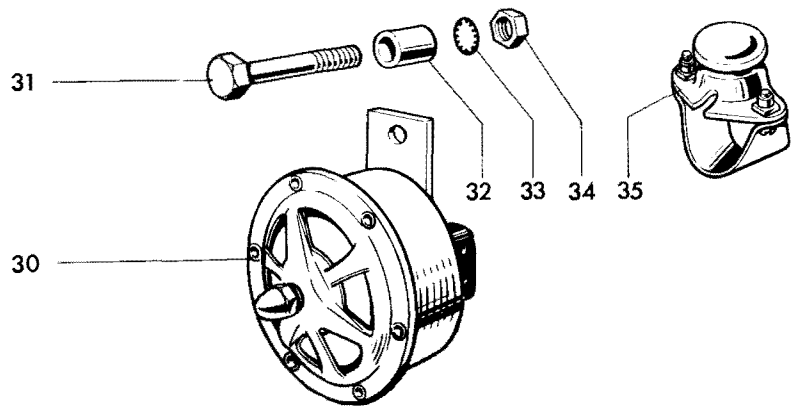
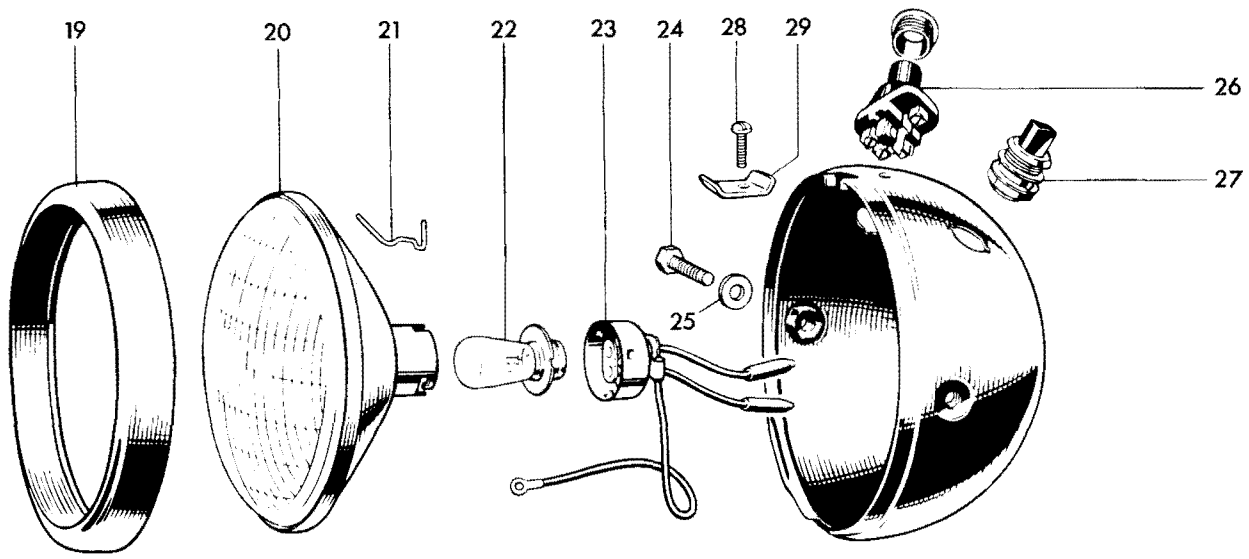
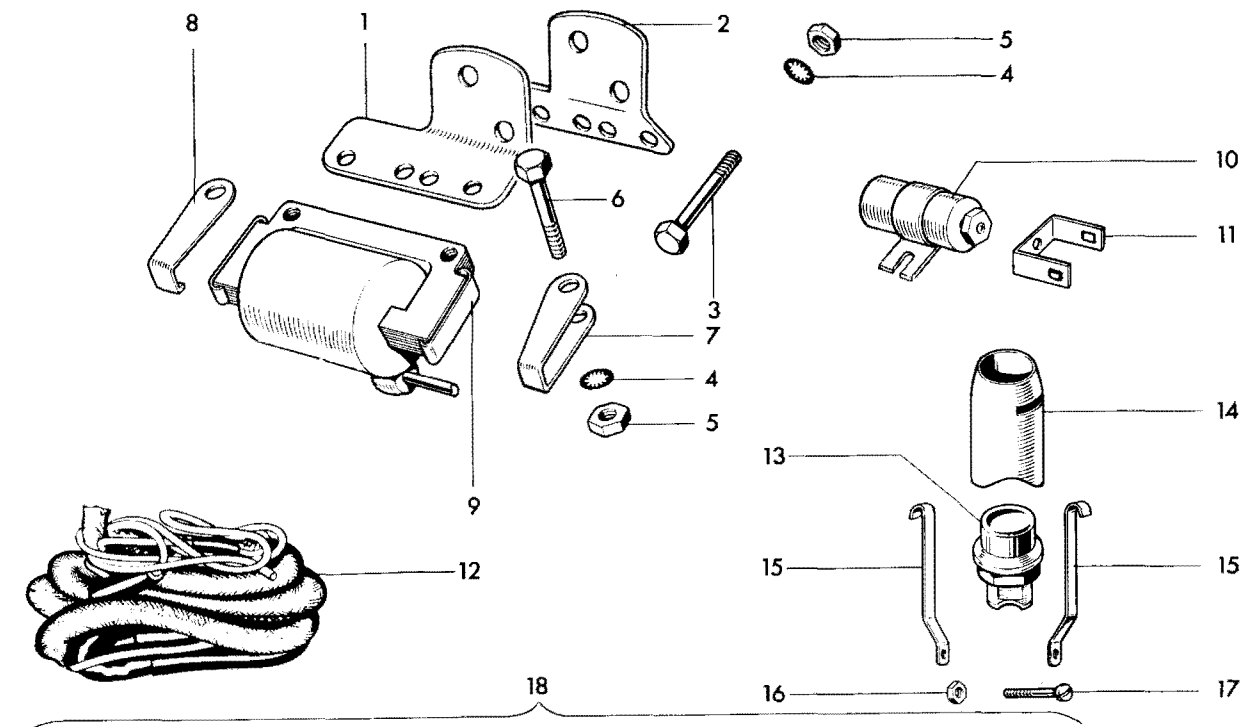

Fig. 38. A.C. MAGNETO IGNITION COILS AND DIRECT LIGHTING

A.C. MAGNETO IGNITION COILS AND DIRECT LIGHTING

1	F6943	Left coil bracket	1	} TR6C & T120TT
2	F6944	Right coil bracket	1	
3	F1369	Bolt ($\frac{5}{8}$ in. U.H.)	2	
4	E1612	Serrated washer	6	
5	S1-40	Nut	6	
6	W932	Bolt (1 in. U.H.)	4	
7	F6125	Retainer	2	
8	F6136	Retainer	2	
9	45149	Ignition coil, type 3ET	2	
10	54441582	Condenser	2	
11	54190108	Lucas terminal	2	} "Kill button"
12	54937097	Wiring harness	1	
13	31071	Cut-out button, type SS5	1	
14	H1669	Cup	1	
15	H1670	Clip	2	
16	H687	Bolt ($\frac{3}{8}$ in. U.H.)	1	
17	H745	Nut	1	
18	58395	HEADLAMP ASSEMBLY, MCH 66	1	
19	534343	Rim	1	
20	54520452	Light unit	1	
21	504665	Fixing wire	6	} Eastern TR6C
22	166	Bulb (24/24W. Pre-focus, Vertical Dip)	1	
23	554602	Adaptor	2	
24	112201	Bolt	2	
25	137499	Washer	2	
26	31356	Lighting switch	1	
27	31620	Dip switch	1	
28	144921	Screw	1	
29	534296	Plate	1	
30	D552	Horn, clear hooters AC585SG	1	
31	11104/06/2	Bolt	1	} Except for bulb See Page 99
32	F4366	Distance piece	1	
33	E1612	Serrated washer	1	
34	15104/00/2	Nut	1	
35	D553	Horn push, clear hooters No. 10	1	
36	53972	STOP AND TAIL LAMP, Type 679	1	
37	384	Bulb (6/18W. Offset pin)	1	

36 and 37 not illustrated.

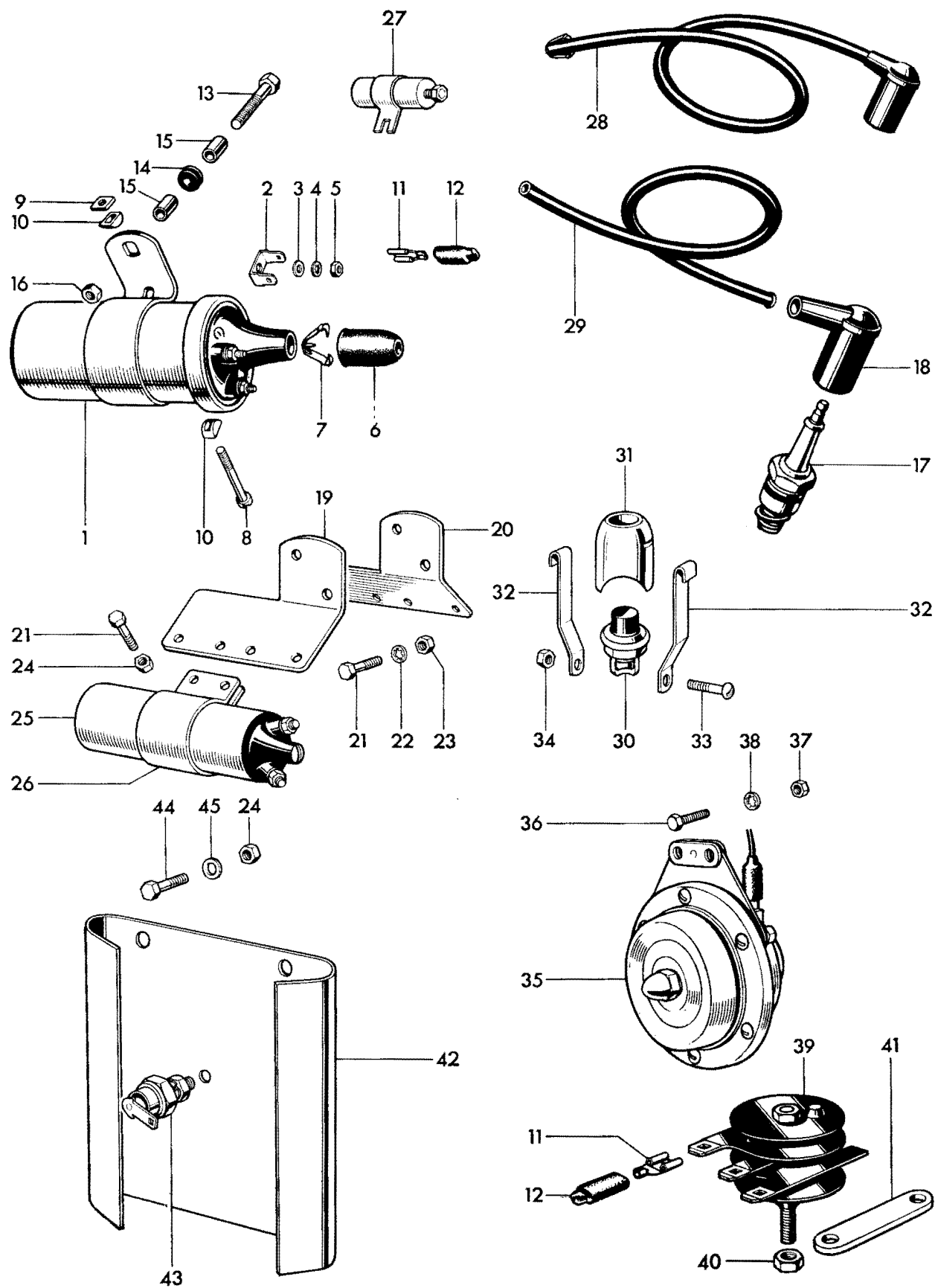

Fig. 39. D.C. IGNITION COILS, HORN, RECTIFIER AND ZENER DIODE

D.C. IGNITION COILS, HORN, RECTIFIER AND ZENER DIODE

1	45110	IGNITION COIL, Type MA12	2	} 6T, TR6, TR6R & T120
2	54190108	Lucar terminal	4	
3	131023	Plain washer (E2351)	4	
4	188330	Serrated washer (GS299)	4	
5	166043	Nut (F3799)	4	
6	421554	Rubber grommet	2	
7	421863	Cable clip	2	
8	100104	Screw	2	
9	169160	Square nut	2	
10	422369	"D" washer	4	
11	54942078	Lucar connector		as required
12	54190042	Insulating cover		as required
13	F4744	Bolt (1 $\frac{5}{16}$ in. U.H.)	2	
14	F5466	Rubber grommet	2	
15	F4366	Distance piece	4	
16	E3290	Self locking nut	2	
17	—	Sparking plug (Champion N4)	2	N58R for T120TT
18	D262	Plug cover	2	
19	F6943	Left coil bracket	1	} T120R
20	F6944	Right coil bracket	1	
21	F1369	Bolt ($\frac{5}{8}$ in. U.H.)	6	
22	E1612	Serrated washer	2	
23	S1-40	Nut	2	
24	F879	Nut	6	
25	E6388	Ignition coil, Siba 32,000	2	
26	E6389	Clip, Siba 32,000/1	2	
27	54441582	Condenser	2	TR6, TR6R, T120, T120R
28	54937976	H.T. lead complete (resistive)	2	TR6, T120
29	842183	H.T. lead (7 m.m. cable)	2	TR6R, T120R
30	35601	Cut-out button, type SS5	1	"Kill button"
31	H1669	Cup	1	
32	H1670	Clip	2	
33	H687	Bolt ($\frac{3}{8}$ in. U.H.)	1	
34	H745	Nut	1	
35	70164	Horn, type 8H	1	
36	F4771	Screw ($\frac{3}{8}$ in. U.H.)	2	
37	F3799	Nut	2	
38	GS299	Serrated washer	2	
39	49072	Rectifier, type 2DS 506	1	
40	F5338	Nut (156 596)	1	
41	F6896	Bracket	1	
42	F6900	Mounting plate	1	
43	49345	Zener diode	1	
44	DS57	Bolt ($\frac{7}{16}$ in. U.H.)	2	
45	S25-1	Washer	2	

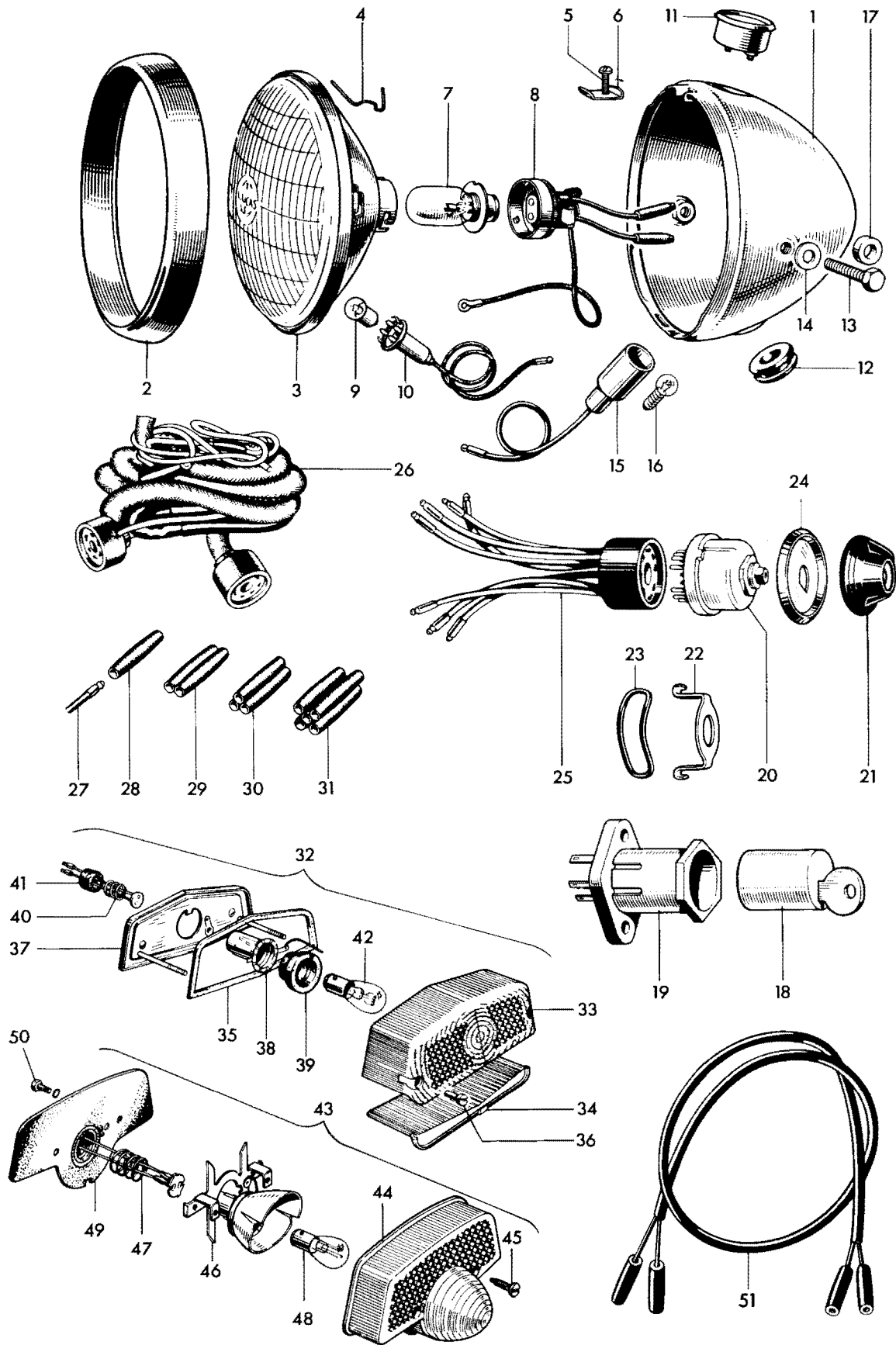

Fig. 40. HEADLAMP, WIRING HARNESS, SWITCHES AND TAIL LAMP

HEADLAMP, WIRING HARNESS, SWITCHES AND TAIL LAMP

1	59579	HEADLAMP COMPLETE	1	
2	553248	Rim...	1	
3	516798	Light unit	1	
4	504665	Fixing wire...	6	
5	144921	Screw	1	
6	534296	Plate	1	
7	446	Bulb (50/40 W. Vert dip. Pre-focus)	1	
8	554602	Main bulbholder	1	
9	988	Bulb (3W. M.C.C.)	1	
10	554710	Pilot bulbholder	1	
11	36296	Ammeter, type 2AR	1	
12	862217	Grommet	1	
13	112201	Bolt	2	
14	137499	Plain washer	2	
15	38189	Ignition warning light body	1	
16	281	Bulb (2W. BA7S)	1	
17	H1932	Headlamp spacer	2	
18	F6981	Ignition lock c/w two keys	1	
19	31899	Ignition switch, type S45	1	
20	34289	Lighting switch, type 88SA	1	
21	54330934	Knob c/w screw	1	
22	F5983	Bracket	1	
23	F5988	Rubber band	1	
24	54330576	Switch bezel plate	1	
25	54930007	Replacement harness socket (Lighting)	1	
26	54938941	Wiring harness	1	
27	900269	Snap connector terminal		as required
28	900288	Single snap connector		as required
29	850641	Double snap connector		as required
30	850844	Triple snap connector		as required
31	850832	Quintuple snap connector		as required
32	53454	STOP AND TAIL LAMP, Type 564	1	} TR6, T120
33	573839	Lens	1	
34	575200	Window	1	
35	575208	Lens seating gasket	1	
36	575219	Sleeve nut	2	
37	576002	Base assembly	1	
38	575209	Bulbholder	1	
39	575207	Grommet	1	
40	573828	Contact assembly	1	
41	573825	Grommet	1	
42	380	Bulb (6/21W. Offset pin)	1	} TR6R, T120R
43	53973	STOP AND TAIL LAMP, Type L679	1	
44	54572932	Lens	1	
45	572289	Screw	2	
46	54574348	Bulb holder with reflector	1	
47	573828	Contact assembly	1	
48	380	Bulb (6/21W. Offset pin)	1	
49	54571677	Gasket	1	
50	127684	Screw	2	
51	838604	Stop and tail lamp lead	1	



REPLACEMENT PARTS CATALOGUE

No. 3

**650 c.c. MOTORCYCLES
SUPPLIED TO THE UNITED STATES**

In 1965 the Triumph factory issued this 4-page supplement to the standard B-range (650 twins) parts catalog that outlined special components fitted only to US models. This addendum also detailed the variations between the American East and West coast T120C and TR6SC models. Rather than page numbers, the supplement corresponds to figure illustrations within the spares catalog. However the TT Special was made available on both coasts in it's offroad form and the "E" and "W" classifications are somewhat misleading. Users of this chart can identify TT Special part numbers wherever the letter "W" relates to the T120C column, while the letter "E" indicates a component for the Bonneville street scrambler. The same method can be employed to separate the Trophy Special part numbers from those of the TR6SC street model.

	Item	Part No.	Description	6T	TR6R	T120R	TR6C	T120
Fig. 1	13	CP202	Piston, 11:1 C.R.	W -	-	-	-	2
	20	E5450	Engine sprocket, 29 teeth DUPLEX ...	W -	-	-	1	1
	21	E4912	Distance piece	W -	-	-	1	1
	—	E4913	Dowel	W -	-	-	1	1
Fig. 5	23	54215824	Rotor, type RM19	W -	-	-	1	1
	9	E5727	CYLINDER HEAD ASSEMBLY	W -	-	-	-	1
Fig. 6	12	E5351	Carburettor adaptor, left	W -	-	-	-	1
	13	E5352	Carburettor adapter, right	W -	-	-	-	1
Fig. 8	11	47602	CONTACT BREAKER, type 4 CA	W -	-	-	1	1
	29	45149	IGNITION COIL, type 3ET	W -	-	-	2	2
	—	F6112	Coil bracket	W -	-	-	4	4
	41	F1756	Bolt ($\frac{3}{8}$ in. U.H.)	W -	-	-	2	2
	—	W932	Bolt (1 in. U.H.)	W -	-	-	4	4
	—	F6125	Retainer	W -	-	-	2	2
	—	F6136	Retainer	W -	-	-	2	2
	—	S25-43	Plain washer	W -	-	-	2	2
	—	F879	Nut	W -	-	-	7	7
	—	E1612	Serrated washer	W -	-	-	8	8
	—	54441582	Condenser	W -	-	-	2	2
	—	DS57	Bolt ($\frac{1}{16}$ in. U.H.)	W -	-	-	1	1
	45	—	Sparking plug, Champion N58R	W -	-	-	-	2
	Fig. 8	3	T1912	Mainshaft high gear	E -	-	-	1
6		T968	Mainshaft second gear	E -	-	-	1	-
9		T974	Layshaft second gear	E -	-	-	1	-
11		T1844	Layshaft c/w high gear	E -	-	-	1	-
12		T973	Speedometer pinion	E -	-	-	1	-
14		T1820	Speedometer gear	E -	-	-	1	-
—		T1227	Blanking nut (speedo drive)	W -	-	-	1	1
21		T1917	Gearbox sprocket (18 teeth)	E -	-	-	1	1
21		T1916	Gearbox sprocket (17 teeth)	W -	-	-	1	1
21		T1952	Gearbox sprocket (15 teeth)	E or W -	-	-	A	A
21	T1953	Gearbox sprocket (26 teeth)	E or W -	-	-	A	A	
Fig. 11	5	D444	Rear chain, 102 links	W -	-	-	1	1
	18	47188	Stator, type RM19	W -	-	-	1	1
Fig. 12	11	F5786	PROP STAND COMPLETE	E & W 1	1	1	1	1
Fig. 13	15	64054164	SUSPENSION UNIT	E & W 2	2	2	2	2
	—	F5686	Rubber grommet (switch holes)	W -	-	-	2	2
Fig. 14	13	F6653	LEFT FOOTREST ASSEMBLY	W -	-	-	1	1
	14	F6654	RIGHT FOOTREST ASSEMBLY	W -	-	-	1	1
	—	F6409	Left footrest	W -	-	-	1	1
	—	F6410	Right footrest	W -	-	-	1	1
	—	F6411	Footrest pedal	W -	-	-	2	2
Fig. 15	—	F6655	Pivot bolt	W -	-	-	2	2
	1	E4884	Left exhaust pipe	E -	-	-	1	1
	1	E4884	Left exhaust pipe	W -	-	-	1	-
	1	F5959	Left exhaust pipe	W -	-	-	-	1
	2	E4886	Right exhaust pipe	E -	-	-	1	1
	2	E4886	Right exhaust pipe	W -	-	-	1	-
	2	E5961	Right exhaust pipe	W -	-	-	-	1
	14	E5866	Silencer	E & W -	2	2	-	-
	14	E4132	Left silencer	E -	-	-	1	1
	14	E4176	Right silencer	E -	-	-	1	1
	—	E4183	Left extension pipe	W -	-	-	1	-
	—	E4184	Right extension pipe	W -	-	-	1	-
	—	E4889	Sleeve nut	E -	-	-	2	2
	—	E4889	Sleeve nut	W -	-	-	2	-
	—	E5963	Stud	W -	-	-	-	1
—	S1-51	Nut	W -	-	-	-	2	
—	E4887	Left stay	E -	-	-	1	1	
—	E4887	Left stay	W -	-	-	1	-	

Item	Part No.	Description	6T	TR6R	T120R	TR6C	T120C
—	E5964	Left stay	W-	-	-	-	1
—	E4981	Right stay	E-	-	-	1	1
—	E4981	Right stay	W-	-	-	1	-
—	E5965	Right stay	W-	-	-	-	1
—	H590	Bolt ($\frac{9}{16}$ in. U.H.)	E-	-	-	2	2
—	H590	Bolt ($\frac{9}{16}$ in. U.H.)	W-	-	-	2	-
—	S26-3	Spring washer	E-	-	-	4	4
—	S26-3	Spring washer	W-	-	-	4	2
—	F929	Bolt ($\frac{1}{2}$ in. U.H.)	E & W-	-	-	2	2
—	E5966	Clip	W-	-	-	-	2
—	T1439	Bolt ($1\frac{3}{16}$ in. U.H.)	W-	-	-	-	2
—	F4299	Plain washer	W-	-	-	-	2
—	S1-51	Nut	W-	-	-	-	2
18	F5087	Left bracket	E-	-	-	1	1
18	F5087	Left bracket	W-	-	-	1	-
18	F5088	Right bracket	E-	-	-	1	1
18	F5088	Right bracket	W-	-	-	1	-
19	H426	Bolt ($\frac{23}{32}$ in. U.H.)	E-	-	-	2	2
19	H426	Bolt ($\frac{23}{32}$ in. U.H.)	W-	-	-	2	-
—	S26-1	Spring washer	E-	-	-	2	2
—	S26-1	Spring washer	W-	-	-	2	-
20	S1-52	Nut	E-	-	-	2	2
20	S1-52	Nut	W-	-	-	2	-
—	E4204	Leg guard	E-	-	-	2	2
—	E4204	Leg guard	W-	-	-	2	-
—	E4207	Clip	E-	-	-	4	4
—	E4207	Clip	W-	-	-	4	-
—	F4715	Screw ($\frac{13}{32}$ in. U.H.)	E-	-	-	4	4
—	F4715	Screw ($\frac{13}{32}$ in. U.H.)	W-	-	-	4	-
—	E2351	Plain washer	E-	-	-	4	4
—	E2351	Plain washer	W-	-	-	4	-
—	F3799	Self locking nut	E-	-	-	4	4
—	F3799	Self locking nut	W-	-	-	4	-

Fig. 17

23A	54336177	Nut, for ignition switch	E 1	-	-	-	-
26A	180316	Nut, for lighting switch	E 1	-	-	-	-

Fig. 18

1	H1925	FORK ASSEMBLY	E & W-	-	-	1	1
8	H1287	TOP LUG c/w CAPS	E & W-	-	-	1	1
—	H506	Caps	E & W-	-	-	2	2
—	S25-3	Plain washer	E & W-	-	-	4	4
12	H1340	Bolt ($1\frac{1}{8}$ in. U.H.)	E & W-	-	-	4	4
18 & 19	H1696	Top cover	E & W-	-	-	2	2
22	H1892	Main spring (Green)	E & W-	-	-	2	2
—	H1913	DAMPER ASSEMBLY	E & W-	-	-	2	2
42	H1893	Restrictor body	E & W-	-	-	2	2
—	H1897	Rod	E & W-	-	-	2	2
—	H1764	Cup	E & W-	-	-	2	2
—	H454	Pin	E & W-	-	-	2	2
—	F879	Nut	E & W-	-	-	2	2
—	H1761	Restrictor body cap	E & W-	-	-	2	2
—	T224	Nut	E & W-	-	-	4	4
34	H1762	Cap nut	E & W-	-	-	2	2

Fig's 19 & 20

FOR FRONT AND REAR WHEELS FOR ALL MODELS EXCEPT EASTERN 6T READ AS FOR TR6.

Fig. 24

23	F6432	AIR FILTER	E & W-	1	-	1	-
23	F6433	AIR FILTER	E-	-	-	-	-
24	F5694	Filter element (paper)	E & W 1	1	-	1	-
—	F5262	AIR FILTER	E & W-	-	1	-	1
—	F5267	Filter element	E & W-	-	1	-	1
—	E5268	Rubber connector	E & W-	-	2	-	2
—	F6036	Clip	E & W-	-	2	-	2
—	F5857	Cap	E & W-	-	2	-	2
—	F4743	Bolt ($2\frac{1}{8}$ in. U.H.)	E & W-	-	2	-	2

Item	Part No.	Description	6T	TR6R	T120R	TR6C	T120C
—	S26-2	Spring washer ...	E & W —	—	2	—	2
—	F879	Nut ...	E & W —	—	2	—	2
—	F6061	Bracket ...	E & W —	—	1	—	1
—	DS57	Bolt ($\frac{7}{16}$ in. U.H.) ...	E & W —	—	1	—	1
18	F4875	Tool carrier ...	W —	—	—	1	1
Fig. 25	—	F5427 Grommet (for switch holes)	E —	—	—	2	2
—	F5366A	TWINSEAT ...	E —	—	1	1	1
Fig. 26	1 & 8	H1677 Front mudguard (undrilled) ...	E 1	1	1	1	1
1 & 8	H1677	Front mudguard (undrilled) ...	W —	1	1	—	—
21	H1678	Bottom stay ...	E & W 1	1	1	—	—
14	H1683	Mudguard bridge ...	E & W 1	1	1	1	1
9	H1685	Bracket ...	E 2	—	—	—	—
12	H1681	Front stay ...	E & W 1	1	1	1	1
8	H1687	Front mudguard (polished) ...	W —	—	—	1	1
13	H1688	Bracket ...	W —	—	—	2	2
21	H1273	Bottom stay ...	W —	—	—	1	1
33	F5955	Mudguard blade (polished) ...	W —	—	—	1	1
43	F6435	Number plate ...	E 1	1	1	1	1
43	F6435	Number plate ...	W —	1	1	—	—
—	F3327	Rubber grommet (rear mudguard) ...	W —	—	—	2	2
Fig. 27	1	H1869 Handlebar ...	E 1	—	—	—	—
1	H1870	Handlebar ...	E & W —	1	1	1	1
3	313/6	Twistgrip ...	E & W —	—	1	—	1
13	18/951	FRONT BRAKE LEVER ASSEMBLY	E & W —	—	1	—	1
14	18/754	Front brake lever ...	E & W —	—	1	—	1
15	18/777	Lever bracket ...	E & W —	—	1	—	1
22	18/838	Cable adjuster ...	E & W —	—	1	—	1
23	18/839	Thumb nut ...	E & W —	—	1	—	1
28	18/952	CLUTCH LEVER ASSEMBLY	E & W —	—	1	—	1
29	18/752	Clutch lever ...	E & W —	—	1	—	1
30	18/773	Lever bracket ...	E & W —	—	1	—	1
Fig. 28	4	D559 Front brake cable ...	E & W 1	1	1	1	1
15	D528	Throttle cable ...	E & W —	—	2	—	2
29	H1580	Steady rubber ...	E & W 2	2	2	—	—
30	H1581	Distance piece ...	E & W 2	2	2	—	—
31	F3814	Cup ...	E & W 2	2	2	—	—
Fig. 30	22	376/100 Main jet, size 270 ...	E & W 1	—	—	—	—
Fig. 31	23	376/100 Main jet, size 310 ...	E & W —	1	—	1	—
23	376/100	Main jet, size 260 ...	E & W —	—	2	—	2
Note: West Coasts T120C has 1 $\frac{3}{8}$ in. carburetter with 330 main jet.							
47	E4918	Insulating block ...	W —	—	—	—	2
48	E4949	Joint washer ...	W —	—	—	—	2
Fig. 32	15	54937097 Wiring harness ...	W —	—	—	1	1
16A	54336177	Nut, for ignition switch ...	E & W —	1	1	—	—
19A	180316	Nut, for lighting switch ...	E & W —	1	1	—	—
—	31376	Cut-out button, type SS5 ...	W —	—	—	1	1
—	H1669	Cup ...	W —	—	—	1	1
—	H1670	Clip ...	W —	—	—	2	2
—	H687	Bolt ($\frac{3}{8}$ in. U.H.) ...	W —	—	—	1	1
—	H745	Nut ...	W —	—	—	1	1
Fig. 33	20	53973 STOP/TAIL LAMP (type 679) ...	E 1	—	—	—	—
20	53972	STOP/TAIL LAMP (type 679) ...	E & W —	1	1	1	1
21	54572932	Lens ...	E & W 1	1	1	1	1
23	54571677	Gasket ...	E & W 1	1	1	1	1
24	572289	Screw ...	E & W 2	2	2	2	2
26	54573248	Bulb holder ...	E & W 1	1	1	1	1
—	F6436	Adaptor ...	E & W 1	1	1	1	1
—	F6438	Distance piece ...	E & W 2	2	2	2	2
—	F6439	Screw ($1\frac{3}{4}$ in. U.H.) ...	E & W 2	2	2	2	2
38A	D546	Rubber plug for tachometer ...	W —	—	—	1	1